



# Operation Manual

---

CPD50L1

---



---

Electric forklift truck

Original Instruction  
V1 11/2023



EP EQUIPMENT CO.,LTD. is one of the world's leading companies manufacture, which design material handling equipment and provide related service. With over 100,000 square metres plant it produces over 100,000 trucks per year, and provides professional, effective and optimized material handling solutions worldwide, until now it has developed three major kinds of business:

- Material handling equipment: Focus on electric forklift and warehouse equipment
- OEM parts: Global parts supply
- Imow industry,online: One-stop industrial products supply

Guided by our customer-oriented concept, EP has developed service centers in more than 30 countries around the world, from which customers are able to receive timely local service. Moreover, 95% of warranty parts can be shipped out within 24 hours after been ordered. Through our online after-sales service system, customers can process their warranty claims, order spare parts and consult the operation manuals, maintenance materials and spare parts catalogs.

With business all over the world, EP has thousands of employees and hundreds of agents worldwide to provide our global customers with prompt local service.

Based on the concept of sharing economy, EP also offer rental service for various logistics equipment. Adhering to the idea "Making the leasing of logistic equipment more simple", EP is devoted to providing customized one-stop leasing solutions for our customers with our high quality, reasonable price and prompt rental service.

EP's mission&vision is " Let more people apply the electrical material handling equipment to relieve the intensity of labour" and "Let's grow together".

EP Equipment Group  
 Alsebergsesteenweg 454A, 1653 Dworp,  
 Belgium

Tel: +32 2 896 5350

E-Mail: [info@ep-equipment.eu](mailto:info@ep-equipment.eu)

EP EQUIPMENT CO., LTD  
 Address: No.1 Xiaquan Village, Lingfeng  
 Street, Anji, Huzhou, Zhejiang

Tel: + 86-0571-28023920

Website: [www.ep-ep.com](http://www.ep-ep.com)

Email: [service@ep-ep.com](mailto:service@ep-ep.com)

## Foreword

The present operation manual is designed to provide sufficient instructions for the safe operation of the industrial truck. The information is provided clearly and concisely.

Our trucks are under ongoing development. EP reserves the right to alter the design, equipment and technical features of the system. No guarantee of particular features of the truck should therefore be assumed from the present operation manual.

### Safety notices and text mark-ups

Safety instructions and important explanations are indicated by the following graphics:



#### **DANGER**

Means that failure to comply can cause risk to life and/or major damage to property.



#### **WARNING**

Please strictly adhere to these safety instructions to avoid personal injury or major damage to equipment.



#### **CAUTION**

Please pay attention to the important safety instructions.



#### **NOTE**

Pay attention to Instruction.

### Internet address and QR code of Parts manual

By entering the address <http://www.ep-care.com> in a web browser or by scanning the QR code, Login after registration, Select "Parts purchase" function and input part number or model name to find the truck.

**NOTE:** After registration, please send email to [info@ep-care.com](mailto:info@ep-care.com) to activate your account



### Conformity marking

The manufacturer uses the conformity marking to document the conformity of the industrial truck with the relevant directives at the time of placing on the market:

- CE: in the European Union (EU)
- UKCA: in the United Kingdom (UK)

The conformity marking is applied to the nameplate. A declaration of conformity is issued for the EU and UK markets.

An unauthorised structural change or addition to the industrial truck can compromise safety, thus invalidating the declaration of conformity.



**ALL RIGHTS RESERVED**

**2023.11 01<sup>st</sup> EDITION**

## Legal requirements for marketing

### Declaration

EP EQUIPMENT CO., LTD.

Address: No.1 Xiaquan Village, Lingfeng Street, Anji, Huzhou, Zhejiang

We declare that the machine

Industrial truck type: corresponding to these this operation manual

Model: corresponding to these this operation manual

Serial No.: corresponding to these this operation manual

Fulfills all the relevant provisions of Directives

- "Machinery Directive 2006/42/EC" <sup>1)</sup>
- "EU directive 2014/30/EU"<sup>1)</sup>
- "Supply of Machinery Safety Regulations 2008( 2008 No. 1597)" <sup>2)</sup>
- "Electromagnetic Compatibility Regulations 2016 (SI 2016 No.1091)"<sup>2)</sup>

Personnel authorised to compile the technical documents:

See EC/EU Declaration of Conformity

EP EQUIPMENT CO., LTD.

1) For the markets of the European Union, the EU candidate countries, the EFTA States and Switzerland.

2) For the United Kingdom market.

The declaration shown explains the conformity with the provisions of the EC Machinery Directive 2006/42/EC and the Supply of Machinery Safety Regulation 2008, 2008 No. 1597. The declaration shown explains the conformity with the provisions of EU directive 2014/30/EU (Electromagnetic Compatibility - EMC) and Electromagnetic Compatibility Regulations 2016, SI 2016 No.1091.

An unauthorised structural change or addition to the industrial truck can compromise safety, thus invalidating the declaration of conformity.

## Table of contents

	Pg.
A Introduction.....	A1
1.1 Intended use.....	A2
1.2 Improper use .....	A3
1.3 Forklift truck handover .....	A3
B Truck description.....	B1
1.1 Application .....	B1
1.2 Truck Assemblies .....	B2
1.3 Display and Controls .....	B4
1.3.1 Display .....	B5
1.3.2 Controls .....	B7
1.3.3 Others.....	B12
1.4 Standard version specifications.....	B18
1.4.1 Performance data for standard truck.....	B18
1.4.2 Dimensions.....	B21
1.5 Identification points .....	B22
1.6 Truck data plate .....	B23
1.7 The load capability chart .....	B24
C Safety.....	C1
1.1 Before operation.....	C1
1.2 Safety .....	C1
1.3 Battery Safety.....	C9
1.4 Related Safety Instruction and Standard(For CE).....	C9
D Transport and commissioning.....	D1
1.1 Transport .....	D1
1.2 Use a hoist to lift the truck.....	D1
1.3 The structure and stability of truck.....	D3
1.4 Commissioning.....	D6
1.5 During running-in.....	D6
E Operation .....	E1
1.1 Checks and operations to be performed before starting daily work .....	E1
1.1.1 Switching on the truck .....	E1
1.2 Driving, Steering, Braking .....	E2
1.3 Loading.....	E3
1.4 Parking the truck securely .....	E6
1.5 Driving on ascending and descending gradients.....	E7
1.6 Operator daily checklist .....	E8
F Battery Maintenance & Charging .....	F1
1.1 Battery type & dimension .....	F1
1.2 Charging the battery .....	F2
1.3 Battery removal and installation .....	F3
G Truck maintenance .....	G1
1.1 Operational safety and environmental protection.....	G1
1.2 Maintenance safety regulations.....	G1
1.3 Servicing and inspection.....	G2
1.3.1 Maintenance checklist.....	G3
1.3.2 Lubrication points .....	G6
1.4 Maintenance instructions.....	G9
1.4.1 Steer wheels removal and installation.....	G9

## Table of contents

	Pg.
1.4.2 Drive wheels removal and installation .....	G10
1.4.3 Checking whether the Drive Axle is leaking.....	G11
1.4.4 Checking the counterweight, motors, chassis, speed reduction gearbox, overhead guard and steering axle fastenings .....	G11
1.4.5 Check the hydraulic oil level.....	G12
1.4.6 Check the electrical fuses.....	G13
1.4.7 Fork Inspection.....	G13
1.4.8 Lift Chain Inspection and Lubrication .....	G14
1.4.9 Inspect the drive and steer wheels and tires every day before operating the lift truck..	G15
1.5 Cleaning .....	G16
1.6 Decommissioning the trucks.....	G17
1.6.1 Prior to decommissioning .....	G17
1.6.2 Restoring the truck to operation after decommissioning .....	G17
1.7 Final decommissioning, disposal.....	G18
1.8 Bolt tightening torque table.....	G18
H Troubleshooting .....	H1
Appendix .....	I1
I Lithium battery operating instructions .....	I2
1.1 Lithium battery use and maintenance manual.....	I2
1.2 Safety and warning.....	I3
1.3 Hazard of faulty or discarded battery.....	I5
1.4 Instructions .....	I6
1.4.1 Battery indicator.....	I6
1.4.2 Lithium Battery Nameplate .....	I8
1.4.3 Charging .....	I9
1.5 Storage .....	I10
1.6 Transportation.....	I10
1.7 Instructions for disposal.....	I11
1.8 Common Problems and Solutions .....	I12
1.9 Service .....	I13

## A Introduction

The truck described in the present operator manual is an industrial truck designed for lifting and transporting load units.

It must be used, operated and maintained according to the information in this operation manual. Any other uses are outside the design envelope and can lead to injury to persons or damage to equipment and property. Above all, overloading caused by excessively heavy or unbalanced loads must be avoided. The max. admissible load to be picked up is indicated on the nameplate or load diagram label shown on the truck. The truck has been passed CE certification.

### Duties of the user

For the purposes of the present operating instructions, the operating company is defined as any natural or legal person who either uses the truck himself, or on whose behalf it is used. In special cases (e.g. leasing or renting), the operating company is considered to be the person who is to carry out the specified operational duties in accordance with existing contractual agreements between the owner and operator of the industrial truck.

The operating company must ensure that the truck is used only for its intended purpose and that dangers to the health and safety of the operator and third parties are prevented. Further more, accident prevention regulations, safety regulations and operating, servicing and repair guidelines must be followed. The operating company must ensure that all operator have read and understood these operating instructions.

### Mounting of attachments

The mounting or installation of any attachments which will interfere with, or supplement, the functions of the truck is permitted only after written approval by the manufacturer has been obtained. If necessary, the approval of local authorities has to be obtained. Any approval obtained from local authorities does not, however, make the approval by the manufacturer unnecessary. Check that loads are handled safely before commissioning a truck with attachments. It may be necessary to make adjustments, depending on the type of attachment, e.g. to pressure settings or adjusting stops and operating speeds.

### Modification

Unauthorized modification to the truck can result in injury or death.

Can not remove, disable or modify any safeguards or other safety devices. These include any alarms, lights, mirrors, overhead guards, and load backrest extensions. If present, an overhead guard is intended to provide protection to the operator from falling objects, but cannot protect from every possible.

**Exception:** Only in the event that the truck manufacturer is no longer in business and there is no successor in the interest to the business, may the user arrange for a modification or alteration to a powered industrial truck, provided, however, that the user

- a) arranges for the modification or alteration to be designed, tested and implemented by an engineer(s) expert in industrial trucks and their safety.
- b) maintains a permanent record of the design, test(s) and implementation of the modification or alteration.
- c) approves and makes appropriate changes to the capacity plate(s), decals, tags and instruction handbook.
- d) affixes a permanent and readily visible label to the truck stating the manner in which the truck has been modified or altered, together with the date of the modification or alteration and the name and address of the organization that accomplished those tasks.

### **Safety devices and warning labels**

The safety devices, warning signs and warning instructions in the present operating instructions must be strictly observed.

**Hazardous area:** A hazardous area is defined as the area in which a person is at risk due to truck movement, lifting operations, the load handler (e.g. forks or attachments) or the load itself. This also includes areas which can be reached by falling loads or lowering operating equipment. Unauthorized persons must be kept away from the hazardous area.

Where there is danger to personnel, a warning must be sounded with sufficient notice.

Give a warning signal with plenty of time for people to leave.

If unauthorized personnel are still within the hazardous area stop the truck immediately.

## **1.1 Intended use**

- The industrial truck is used for moving and lifting the loads indicated on the capacity rating plate.
- Damages and other defects to industrial trucks or to attachments must be reported to the supervisor immediately. Industrial trucks and attachments which are not safe to operate may not be used until they have been properly repaired.
- Safety installations and switches may not be removed or rendered unusable. Specified settings may only be changed with the approval of the manufacturer.
- Only the areas approved by the operating company or its representative may be used for transportation purposes. Loads may only be deposited or stored at the intended places.
- Inclines used by industrial trucks shall not exceed the limits specified by the manufacturer and must have an adequately rough surface.



- Danger points on driving lanes or routes shall be secured or marked by the customary road traffic signs and by additional warning signs, if necessary.
- Driving routes shall be sufficiently paved, level and free of objects. Drain channels and railways crossings, etc., shall be levelled and, if necessary, covered with ramps in such a way that they can be driven over without bumps as far as possible.  
The EU Directive 89/654/EEC (Minimum Regulations for Health and Safety for the workplace) shall be observed. The respective national regulations apply for non-EU countries.
- When driving on public roads, the corresponding regulations must be observed, as well as country-specific restrictions for winter road conditions.
- The operating company is responsible for adequate fire protection in the vicinity of the industrial truck.
- Industrial trucks may only be used to tow trailers if they are intended for this purpose by the manufacturer . The maximum towed load specified in the operating instructions for unbraked or braked trailers must not be exceeded. The towing industrial truck must be operated in such a way that safe driving and braking of the towed vehicle is ensured for all driving movements.

## 1.2 Improper use

The operating company or driver, and not the manufacturer, is liable if the truck is used in a manner that is not permitted. The following list is exemplary and is not intended to be exhaustive.

- Do not stack loads or turn when driving on a ramp.
- Never park the truck in a place that may obstruct fire extinguishers, fire escapes or aisles.
- Do not leave the truck unattended when the load is raised.
- Do not stand on the fork arms when raised.
- Do not increase the truck's load capacity, e.g. by attaching an additional weight.

## 1.3 Forklift truck handover

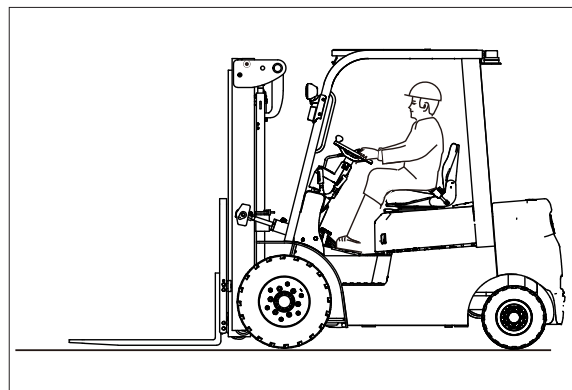
To avoid the inconvenience of making a claim after use, check the forklift truck is in perfect condition and repair, and confirm your satisfaction with the vehicle on the manufacturer's product qualification certificate upon handover.

## 1.4 Schematic views

View of functions and operations  
This documentation explains the (usually sequential) chain of certain functions or operations. Schematic diagrams of a counterbalance truck are used to illustrate these procedures.

### **i** NOTE

*These schematic diagrams are not representative of the structural state of the documented truck. The diagrams are used solely for the purpose of clarifying procedures.*



## B Truck Description

### 1.1 Application

High ground clearance and big tires perfect for handling and traction in every environment. Great ergonomic design with spacious legroom, adjustable steering wheel and comfortable bucket seat 80V Li-Ion battery grant efficiency, long autonomy and opportunity charging. With maximum economic efficiency, safety and driving comfort. It adopts LFP Lithium-ion battery that prevent the battery from self- ignition and ensures safety operation. Comparing to a diesel forklift truck, it saves 30%-50% of energy cost with Lithium-ion technology. It also offers option of manufacturer's latest telematics and provides the following features to facilitate your fleet management:

- Truck location in real-time
- *Reports of truck usages and diagnosis*
- Li-ion battery condition analytics
- Updates on card access registration
- Used in specified area as factory, tourist attraction and recreation place.
- Indoor and outdoor use.
- The truck's max operation altitude is up to 2000m.
- The lowest environment temperature under normal outdoor conditions when operation  $-20^{\circ}\text{C}$  .
- Average environment temperature under continuous operating condition  $+25^{\circ}\text{C}$  .
- The highest environment temperature in the short term ( $\leq 1\text{h}$ )  $+40^{\circ}\text{C}$  .
- The lowest environment temperature under normal indoor conditions when operation  $+5^{\circ}\text{C}$  .
- Do not negotiate inclines crosswise or at an angle. Transporting loads downhill.
- If you must travel on an incline, the gradients should be below A% at full load, or below B% without a load. (For the value of A and B, refer to the gradeability in Standard Version Specifications)
- IPX4 waterproof rating.

#### **i** NOTE

*The truck may only be operated in cold stores temporarily as the permissible battery operating temperature is between  $0^{\circ}\text{C}$  and  $40^{\circ}\text{C}$  . If the truck remains in a cold store, we recommend with special measures for the truck or buy cold store truck.*

Lithium-ion battery working temperature is divided into charging temperature requirement and discharging temperature requirement:

The charging temperature range is  $0^{\circ}\text{C}$ - $40^{\circ}\text{C}$ . A high-rate recharging operation below  $0^{\circ}\text{C}$  may lead to battery damage, so we recommend charging temperature range is  $5^{\circ}\text{C}$ - $40^{\circ}\text{C}$ ;

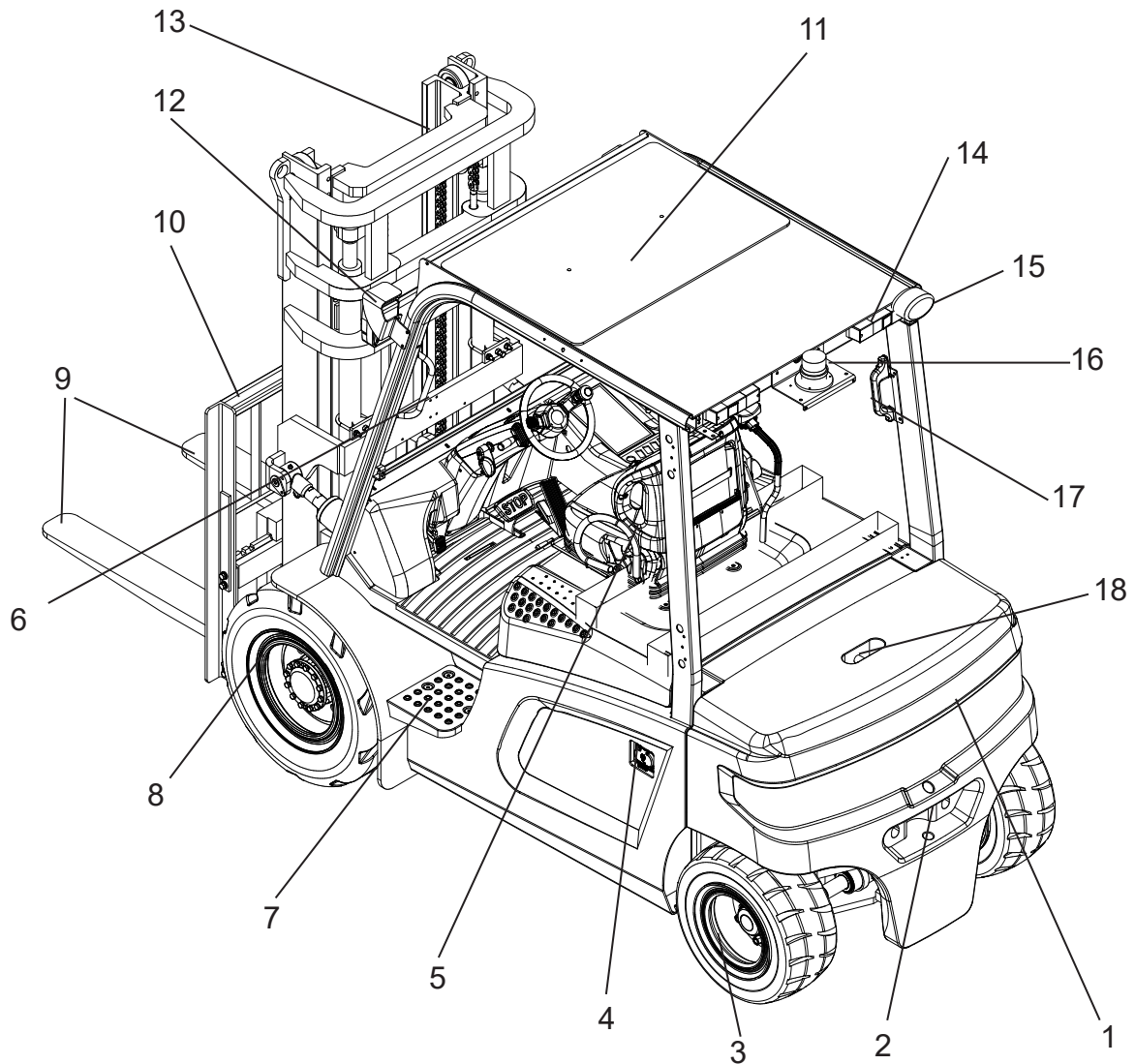
The discharging temperature range is  $-20^{\circ}\text{C}$ - $55^{\circ}\text{C}$ . If used in low temperature  $^{\circ}\text{C}$ - $20^{\circ}\text{C}$ - $0^{\circ}\text{C}$ , battery discharge capacity will be smaller compared with the one in normal temperature condition, which is normal; battery used between  $40^{\circ}\text{C}$ - $60^{\circ}\text{C}$  in the long run will accelerate the aging of the internal material. It may shorten the service life of battery, so not recommended. So we recommend working temperature is  $0^{\circ}\text{C}$ - $40^{\circ}\text{C}$ . Best operating temperature range:  $15^{\circ}\text{C}$ ~ $35^{\circ}\text{C}$ .



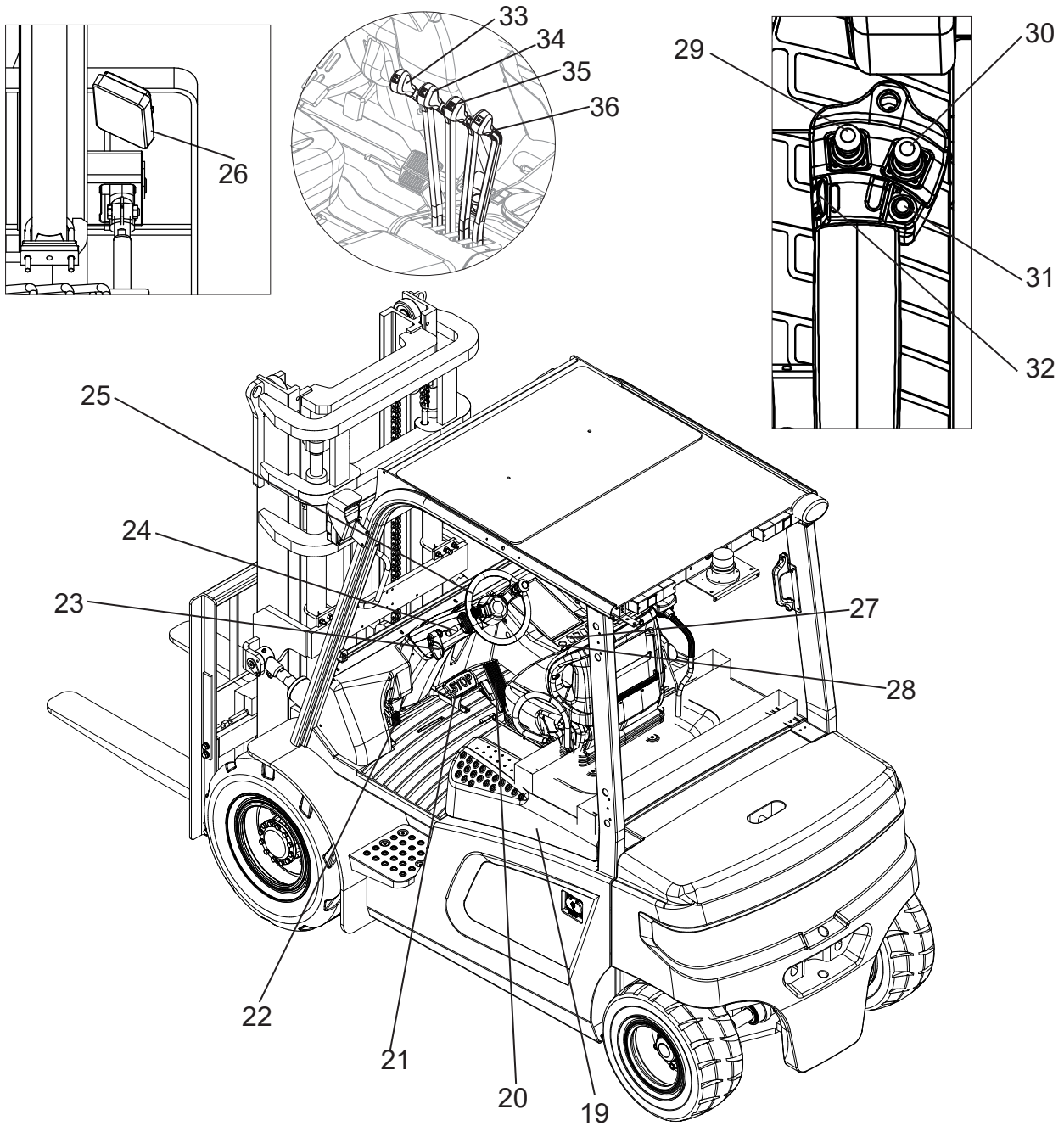
#### **WARNING**

*Operating the truck under extreme conditions can result in malfunctions and accidents. Special equipment and authorization are required if the truck is to be used in extreme conditions, especially in dust-laden or corrosive environments. Operation in explosive atmospheres is not permitted.*

## 1.2 Truck Assemblies

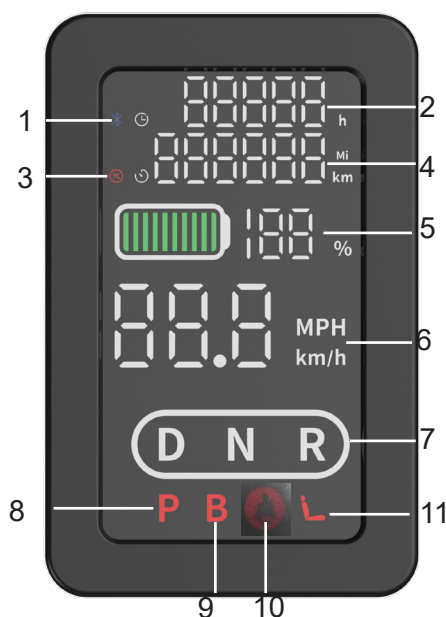


1	Counterweight	10	Load backrest
2	Towing pin	11	Overhead guard
3	Steer wheels	12	Headlight
4	Charging port	13	Mast
5	Seat	14	Rear combination lights
6	Handrail	15	Blue light
7	Safety step	16	Warning light
8	Driving wheels	17	Reversing horn
9	Fork arms	18	Sling point







19	Battery hood	26	Instrument	33	Lifting lever
20	Accelerator pedal	27	Operation button	34	Tilting lever
21	Brake pedal	28	Emergency stop switch	35	Sideshifter leve
22	Parking brake pedal	29	Lifting/Lowering/tilting lever	36	Attachment lever
23	Steering column tilting angle adjuster	30	Attachment/Side lever	37	
24	Travel combination switch	31	Horn button	38	
25	Steering wheel	32	Forward and Backward button	39	

### 1.3.1 Display



item	ICON	EXPLANATION
1		(1) display Bluetooth
2		(2)display full working hours The blue light will light up when the Bluetooth is connected, and will go out when the connection is lost.
3		(3) display the fault code
4		(4) display total kilometres timetable, When no fault occurs,LED (4) display total kilometres timetable, If fault, LED (3) lit up and display the fault code.
5		(5) displays the remaining charge,The value on the right is the percentage of electric capacity, and the number of electric capacity bars (0-10 bars) on the left is different according to the remaining electric capacity.
6		(6) displays speed value, and the right side is the speed unit, which can be changed to MPH or km/h according to customer requirements.
7		If this icon N is showed, it means the direction switch is in normal position. If this icon D is showed, it means the direction switch is in forward position. If this icon R is showed, it means the direction switch is in reverse position.

Item	ICON	EXPLANATION
8		<b>Parking brake indicator</b> This lamp illuminates whenever the parking brake is applied.
9		<b>Service brake indicator</b> This lamp illuminates whenever the service brake is work.
10		<b>Safety belt indicator</b> This lamp illuminates whenever the driver <i>The seat belt is not fastened.</i>
11		<b>Seat indicator</b> This lamp illuminates whenever the driver leaves the seat, indicating that the operator is not sitting in the seat as required

## 1.3.2 Controls

### ➤ Steering

- When the steering wheel is turned right, the forklift will turn to the right;
- when the steering wheel is turned left, the forklift will turn to the left.
- The rear end of the forklift swings out when turning.



### WARNING

The forklift is equipped with a hydraulic steering system that times out when the truck is stationary for a few seconds.

- The steering will be impaired when the hydraulic pump motor stops running.
- The hydraulic pump motor restarts automatically by stepping on the accelerator.
- The steering hydraulic pressure will then reengage.

### ➤ Key switch

The key switch has two positions: ON and OFF.

Truck power supply is cut off when the key turn is turned to "OFF".

Truck power supply is turned on when the key is turned to "ON".

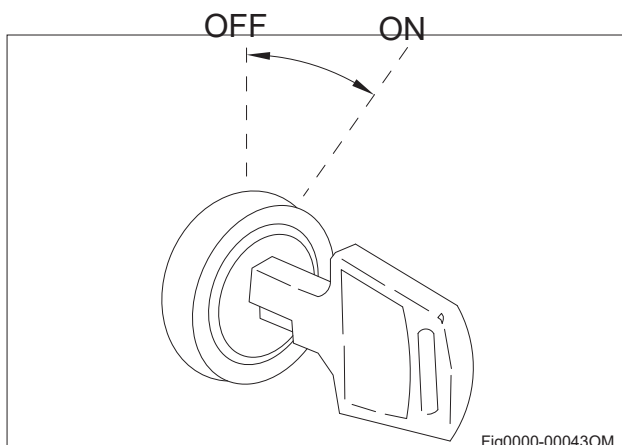
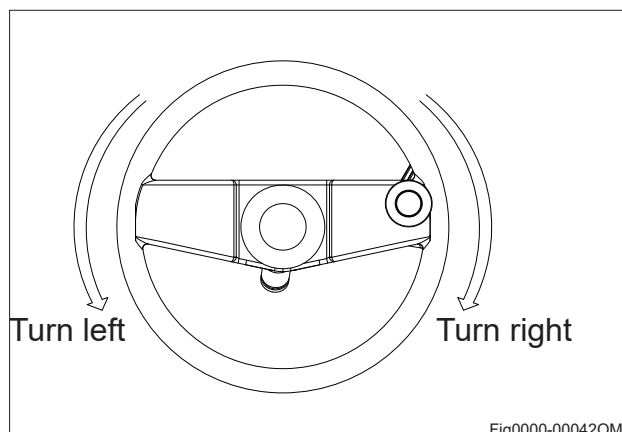
If you start of the truck to drive. First set the combination switch to the neutral position, then take your foot off the accelerator pedal. Turn the key clockwise to the ON position.

Remove the key to prevent the truck from being switched on by unauthorised personnel.



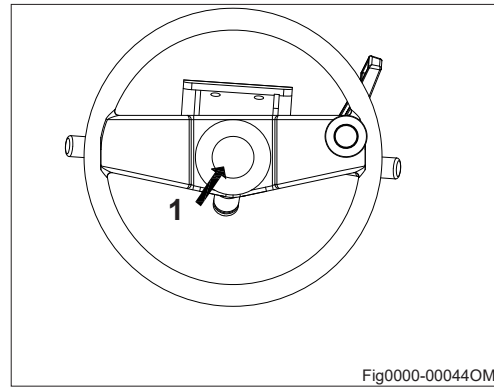
### WARNING

If the combination switch is not in neutral or the accelerator pedal is depressed, the forklift will not start when the key switch is turned to ON. At this point a fault code will be displayed, which is perfectly normal. Return the combination switch to the neutral position and take your foot off the accelerator pedal before attempting to start the forklift. The fault code will then disappear.



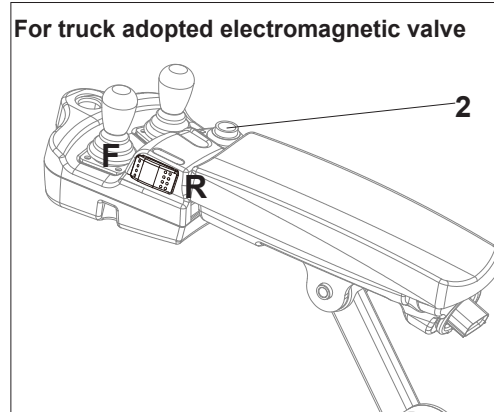
➤ **Horn button**

Press the horn button (1) or (2), the horn sounds.



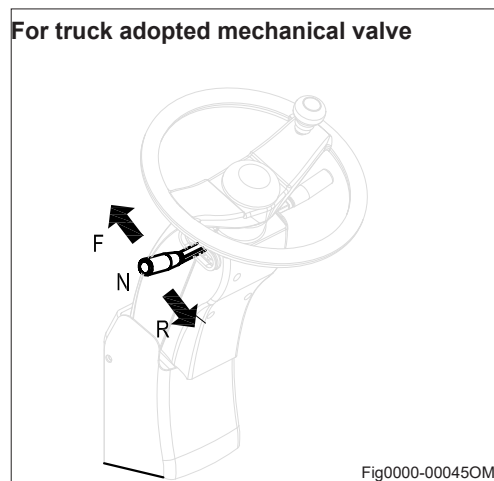
➤ **Travel Combination Switch(Electromagnetic valve)**

For switching travel direction of truck:  
Forward (F) , Reverse (R) and Neutral (N).  
The travel switch is used to switch between forward and reverse directions of travel. When the switch is pressed forward and the accelerator pedal is depressed, the forklift truck will travel forward. When the travel switch is pulled back, the forklift will travel in reverse.



➤ **Travel Combination Switch (Mechanical valve)**

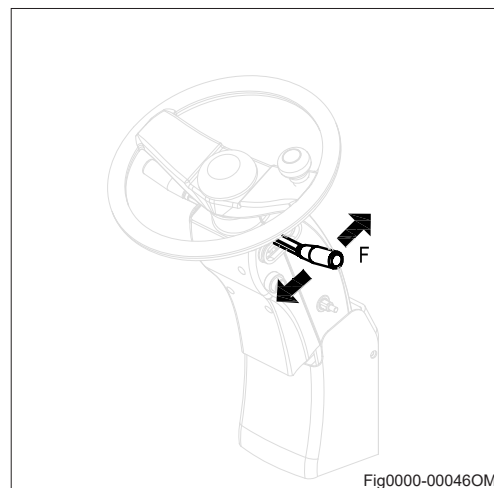
For switching travel direction of truck:  
Forward (F) , Reverse (R) and Neutral (N).  
The travel combination switch is used to switch between forward and reverse directions of travel. When the combination switch is pushed forward and the accelerator pedal is depressed, the forklift truck will travel forward. When the travel combination switch is pulled back, the forklift will travel in reverse.



➤ **Combination light switch**

The combination light switch includes turn signal indicator and light switch.  
Turn signal: Push or pull this switch, the corresponding signal light flashes.

Push Forward	←	Left turn light flashes
Neutral		Off
Pull back	→	Right turn light flashes



**⚠ CAUTION**  
The turn signal lever does not automatically return to the neutral position, reset it by hand.



➤ **Parking brake pedal**

The parking brake pedal must be depressed, when the truck stops. When start the truck, depress parking brake pedal again to release it, the parking brake pedal bounces up.

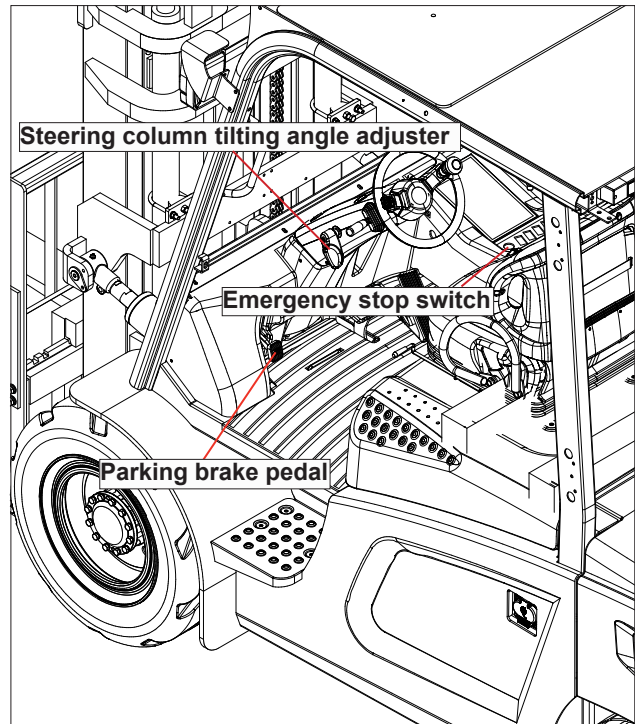
➤ **Emergency stop switch**

In an emergency, press the red mushroom head button to cut off the vehicle's main power supply. The vehicle will not be able to move, turn or lift.



**CAUTION**

*Do not use the emergency stop switch to stop the truck under normal circumstances as the key switch.*



➤ **Steering column tilting angle adjuster**

The tilting angle of the steering column is adjustable with a range of 12.5 degrees to suit individual operators. The steering column is unlocked by turning the right handle counterclockwise and locked by turning the right handle clockwise.

➤ **Brake pedal**

Depressing the brake pedal will slow down or stop the forklift.

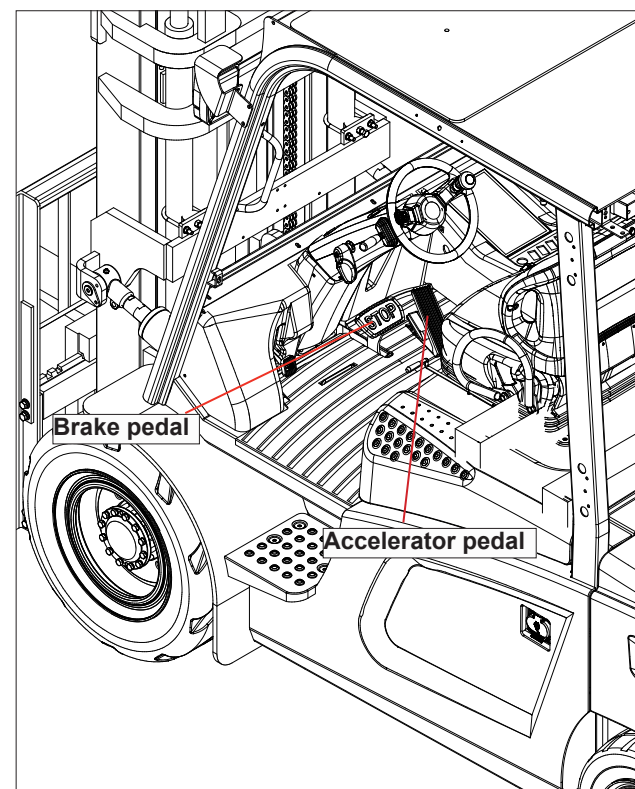


**CAUTION**

*Do not depress the accelerator and brake pedals at the same time, as this will damage the drive motor.*

➤ **Accelerator pedal**

Slowly depress the accelerator pedal, the drive motor will start running and the forklift will move off. The travel speed can be increased gradually based on the force applied to the pedal.



**For truck adopted mechanical valve**

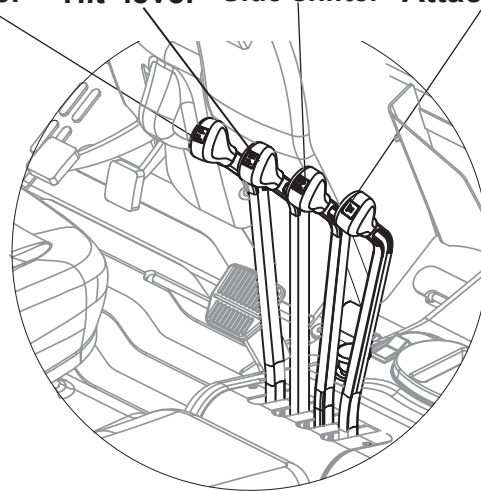
Lift lever    Tilt lever    Side shifter    Attachment lever

➤ **Control lever**

Control levers includes lift lever, tilt lever, sideshifter lever and attachment lever.

➤ **Attachment lever(optional)**

Apply when installing the attachment with 4th valve. Push and pull this lever can apply the attachment function.



➤ **Lift lever**

Pull back to raise the forks. Push forward to lower the forks. The lifting speed depends on the distance that the lever is moved backward. The lowering speed is depends on the distance that the lever is moved forward.

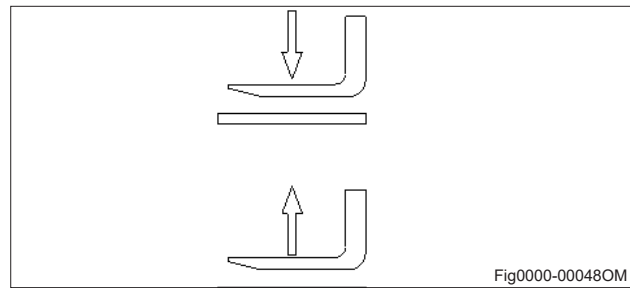


Fig0000-00048OM

➤ **Tilt lever**

The tilt lever is used to tilt the mast forward and backward. Push forward to tilt the mast forward, pull backward to tilt the mast back. The tilting speed is determined by the distance that the lever is moved.

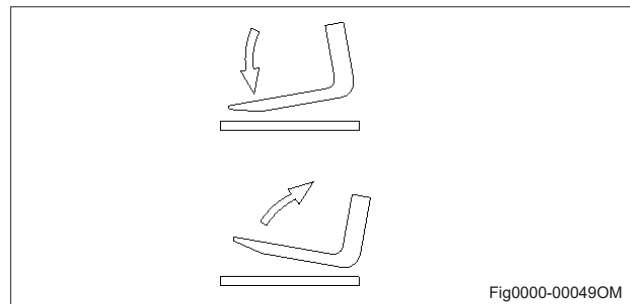


Fig0000-00049OM

➤ **Sideshifter lever (optional)**

Control the fork to move to left or right. Push or pull this lever can make the mast move leftwards/rightwards.

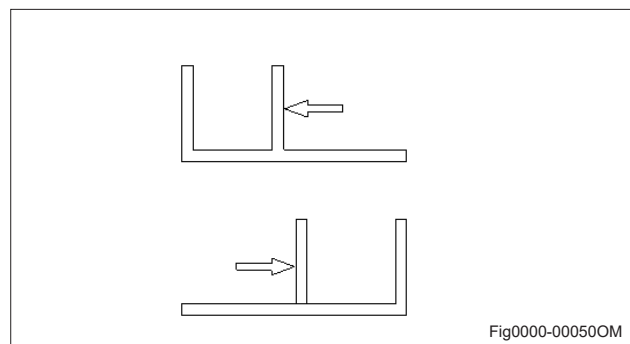
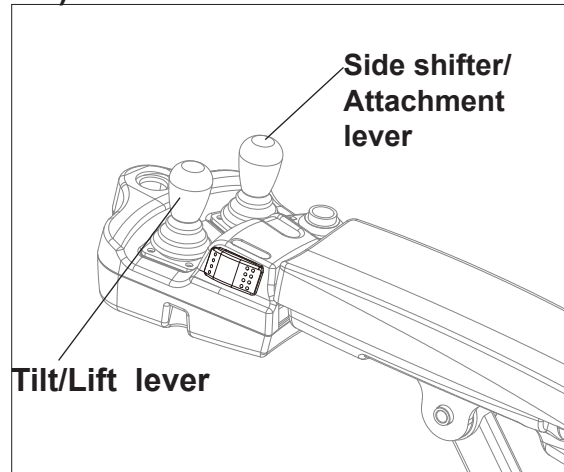


Fig0000-00050OM

**For truck adopted electromagnetic valve(optional)**

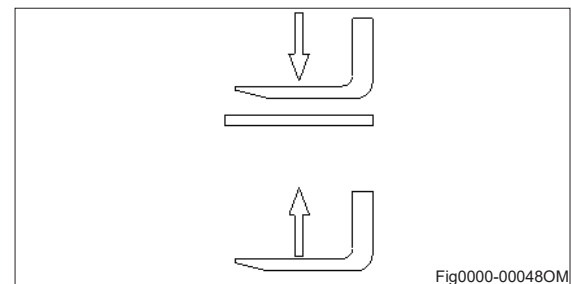
➤ **Control lever**

Control levers includes tilt /lift lever, sidershifter/attachment lever(see the right figure).

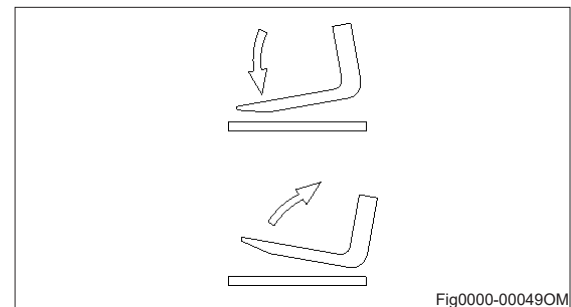


➤ **Lift/ Tilt lever**

Push Tilt/Lift lever leftward to raise the forks. Push Tilt/Lift lever rightward to lower the forks. The lifting speed depends on the distance that the lever is moved leftward. The lowering speed is depends on the distance that the lever is moved rightward.

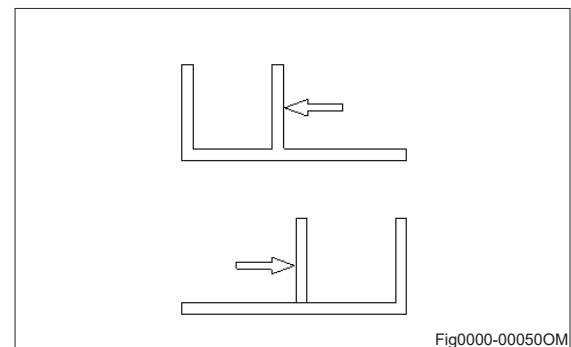


The tilt lever is used to tilt the mast forward and backward. Push Tilt/Lift lever forward to tilt the mast forward, pull Tilt/Lift lever backward to tilt the mast back. The tilting speed is determined by the distance that the lever is moved.



➤ **Side shifter lever**

Control the fork to move to left or right. Push Side shifter/Attachment lever the lever leftward to make fork arms left. Push Side shifter/Attachment leve rightward to make fork arms right.

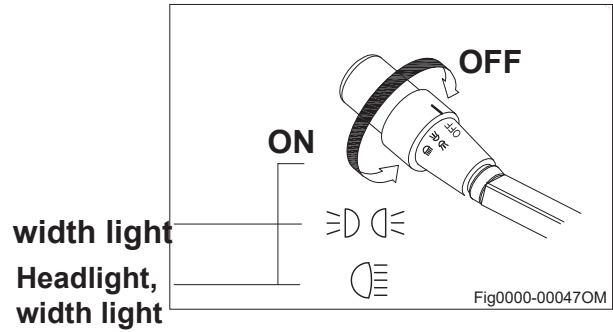


➤ **Attachment lever**

Apply when installing the attachment with 4th valve. Push forward and pull backward this lever can apply the attachment function.

➤ **Light switch:**

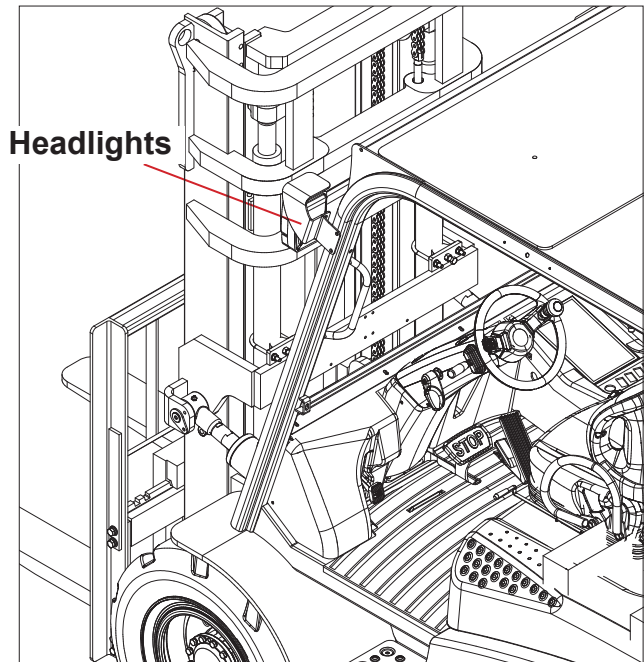
Rotation type switch. Control the light through the knob on the head of Combined lamp switch.



**1.3.3 Others**

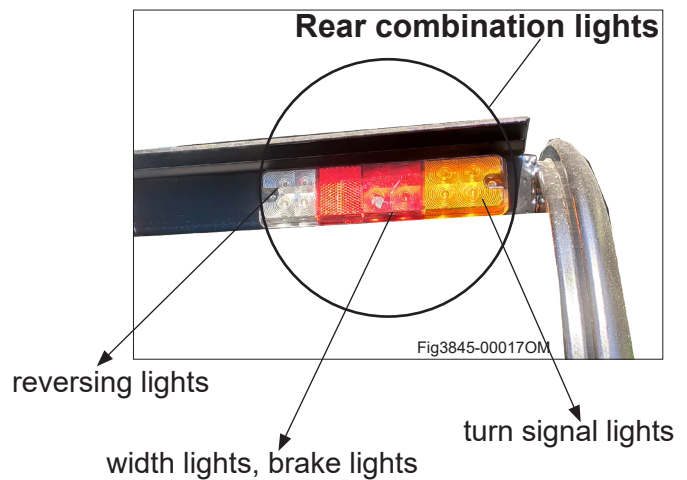
➤ **Headlights**

Headlights are installed on the front pillars of the overhead guard. Protect the lights from damage and clean them up if dusty. Any damaged lights must be replaced.



➤ **Rear combination lights**

The rear combination lights include turn signal lights, show width lights, brake lights and reversing lights. Protect the lights from damage and clean them up if dusty. Any damaged lights must be replaced.



➤ **Fork pin**

Used when adjusting the spacing of the forks. Pull up the fork stopper and rotate it 90°, then adjust the forks to the desired positions according to the load to be handled.

Release pin to lock fork into place.



**WARNING**

*Fork spacing should be adjusted symmetrically to the truck centreline. After adjustment, make sure that the fork stoppers are securely locked.*

*The lower crossbar of the fork carriage has an opening for fitting and removing the forks.*

*Do not secure forks at the opening position, in order to prevent them falling through the opening.*

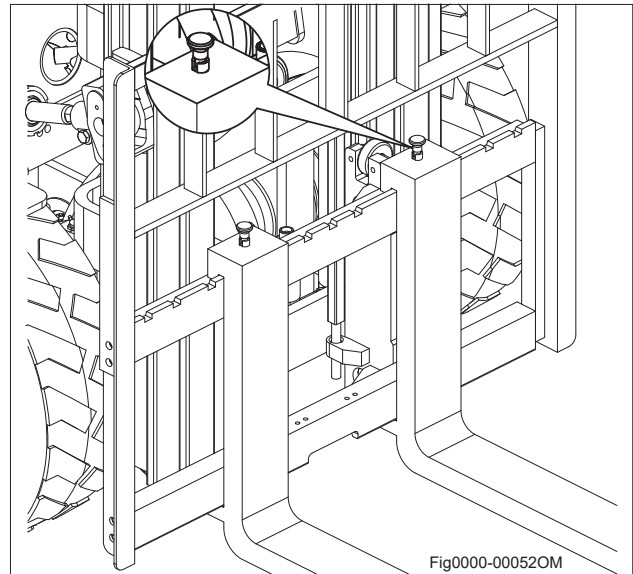
➤ **Air spring**

When opening the battery hood, the air spring is used to support the cover. When closing the battery cover, press the air spring button according to the arrow direction, meanwhile, press the cover hard and lock it with lock catch.

➤ **Battery hood**

Open the snap close(2) first then the hood(1) can be open.

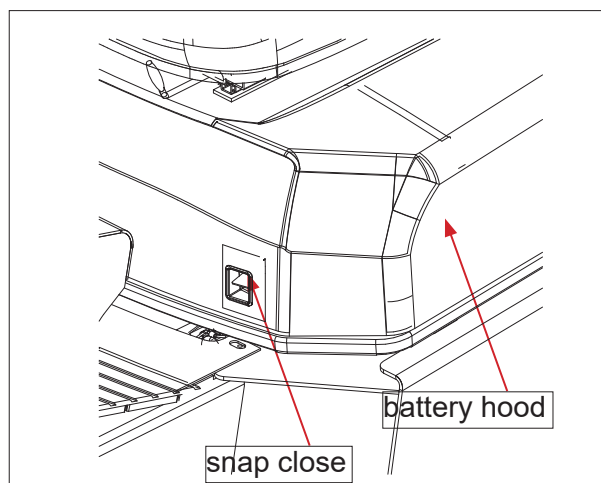
When servicing under the hood, be sure to turn off the key switch to prevent electric shock. However, in the case where the hands, feet, head, and body do not touch the components, in order to diagnose the fault by hearing, the key switch and the hood are allowed to open at this time.



**Air spring**

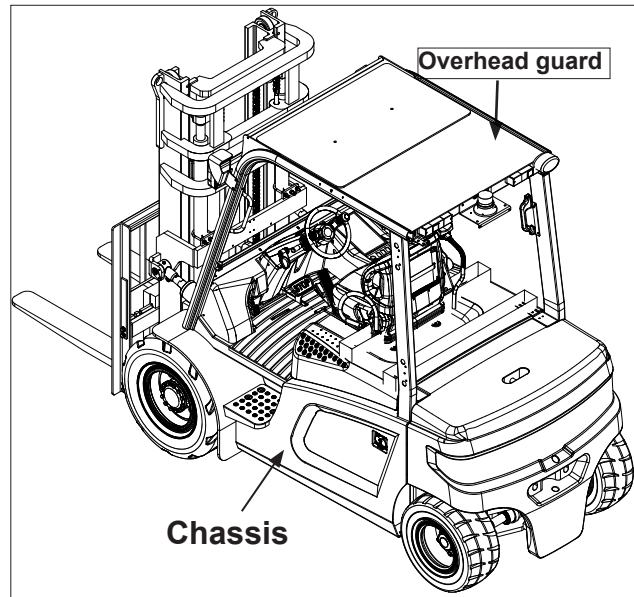


Fig0000-00174OM



➤ **Overhead guard**

The overhead guard protects the operator against injury from falling objects. It must have sufficient impact strength. Its gap is used to lift battery. Do not use the forklift without the overhead guard.

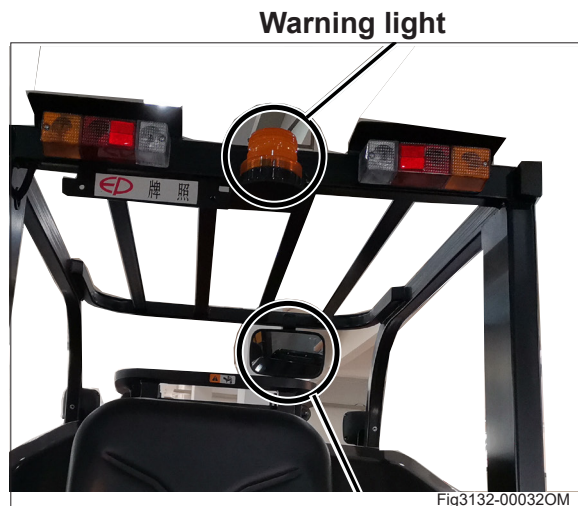


➤ **Chassis**

The chassis, in conjunction with the counterweight, forms the supporting base structure of the truck. It is used to support the main components.

➤ **Warning light**

Press the caution light button, the caution light will flash.



**WARNING**

*When start the truck, you must press the caution light button to keep the caution light on.*

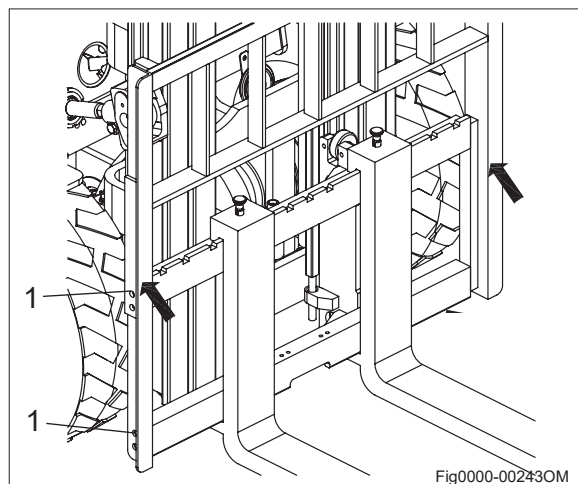
➤ **Rearview mirror**

The steering column is unlocked by turning the right handle counterclockwise and locked by turning the right handle clockwise.

Rearview mirror

➤ **Load backrest**

Load backrest is an important safety part that prevents loads dropping. To protect from falling objects, make sure that the Load Backrest Extension are correctly mounted and in good condition. Unscrew the bolts(1) on the left and right sides of the load backrest, then take off the load backrest.



**DANGER**

*Loads should be arranged so that they do not project beyond the edge of the truck loading surface and cannot slip, topple over or fall off.*

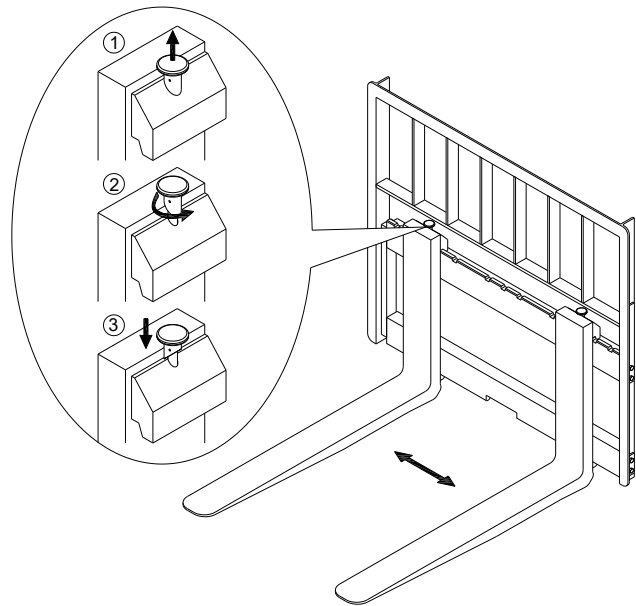
## ➤ Adjust and replace forks

### Adjust fork distance

In order to guarantee safe operation of picking loads, before operation, adjust the fork distance to proper position according to the tray dimension.

#### Procedures

- Pull the fork locating pin upward (1), and rotate 180° in either direction (2) to unlock the fork.
- Based on fork carriage center line, adjust the fork position to both ends symmetrically.
- After adjusting fork distance, make sure the forks are positioned correctly and rotate pin until it drops into place (3).



### CAUTION

*Fork locating pin must be locked(keep in the slot of fork carriage), otherwise forks are easy to move during driving and loads may fall down.*

*Be careful when adjusting forks.*

## ➤ Fork removal

### Fork removal

When replacing forks, screw off the fixed bolt(1) in the middle of the fork carriage, move the fork to the middle opening of fork carriage beam, and then tilt forward and lower the forks until forks are off the fork carriage, then back the truck.



### Fork assemble

Place forks on the ground against the truck, lower the fork carriage to the lowest, drive the truck forward slowly, aim at the upper and lower slot of fork and the upper and lower beam and gap of fork carriage, fully lift the fork carriage, adjust the left and right position of forks. Screw back on the fixed bolt from above to lock in place.

➤ **Seat**

**Adjust seat position**

Pull the driver seat forward-backward with adjusting lever(2), and move the seat forward or backward to proper position. Release the adjusting lever, the driver seat will be locked.



**WARNING**

*Lock the driver seat forward-backward adjusting lever on the set position. Never adjust seat when driving.*

➤ **Adjust seat back**

Driver sits on. Rotate the seat back adjusting knob switch (1) clockwise, and adjust the back inclination. Release the knob switch, the seat back will be locked.

➤ **Safety belt**

Fasten safety belt (3) before driving. It protects driver when accidents happen. Regularly clean and check safety belt, avoid dirt.

➤ **Correctly use safety belt**

Sit on the seat correctly.  
Check if the safety belt twisted.  
Fasten the safety belt and check safety belt lock.

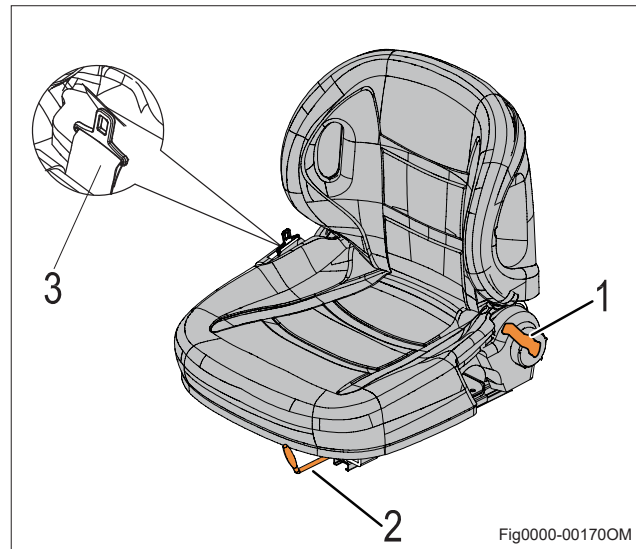
➤ **Periodically check the safety belt**

Check if safety belt is damaged or cracked.  
Check if the metal pieces of safety belt(including anchor point) are worn or damaged.  
Check if lock catch for safety belt or traction machine functions normally.



**WARNING**

*In any case, if there is damage or flaw etc. on the safety belt, please repair or replace it immediately.  
Never do any changes to the safety belt.  
Replace a new one after each accident.*







## **DANGER**

*The seat belt should be fastened when using the forklift truck! The seat belt can only be used by one person. For the driver's safety, the vehicle doors (rigid or folding) must be shut tightly when the truck is in operation.*

### ➤ **Operating attachments**

Attachments are optional equipment purchased by the user and installed onto the truck (for example: lateral forks, clamps etc.). Pay close attention to the working pressures and operating instructions for each attachment. An additional operating lever should be installed for use by the attachments.



## **NOTE**

*After installing each attachment, a label should be attached to the battery hood, explaining the truck's load capacity after installing the attachment. An attachment operating notice should also be attached to the back of the attachment control lever.*



## **CAUTION**

*If the attachment was not supplied with the truck, it can only be used if verified by your dealer and safe operation of the truck is guaranteed in terms of load capacity and stability after installation of the attachment.*

### ➤ **OPS System (option)**

OPS (Operator Presence Sensing) system is a safeguard system if the driver sits on the seat correctly. If the driver does not sit on the seat correctly, driving force is cut off, meanwhile, all loading and unloading operations will be stopped. It helps to reduce accident when the driver leaves. When the driver does not sit correctly, the driver cannot drive the truck or operate the loading and unloading, thus the accidents by maloperation will be reduced.

## 1.4 Standard Version Specifications

Technical specification details in accordance with VDI2198. Technical modifications and additions reserved.

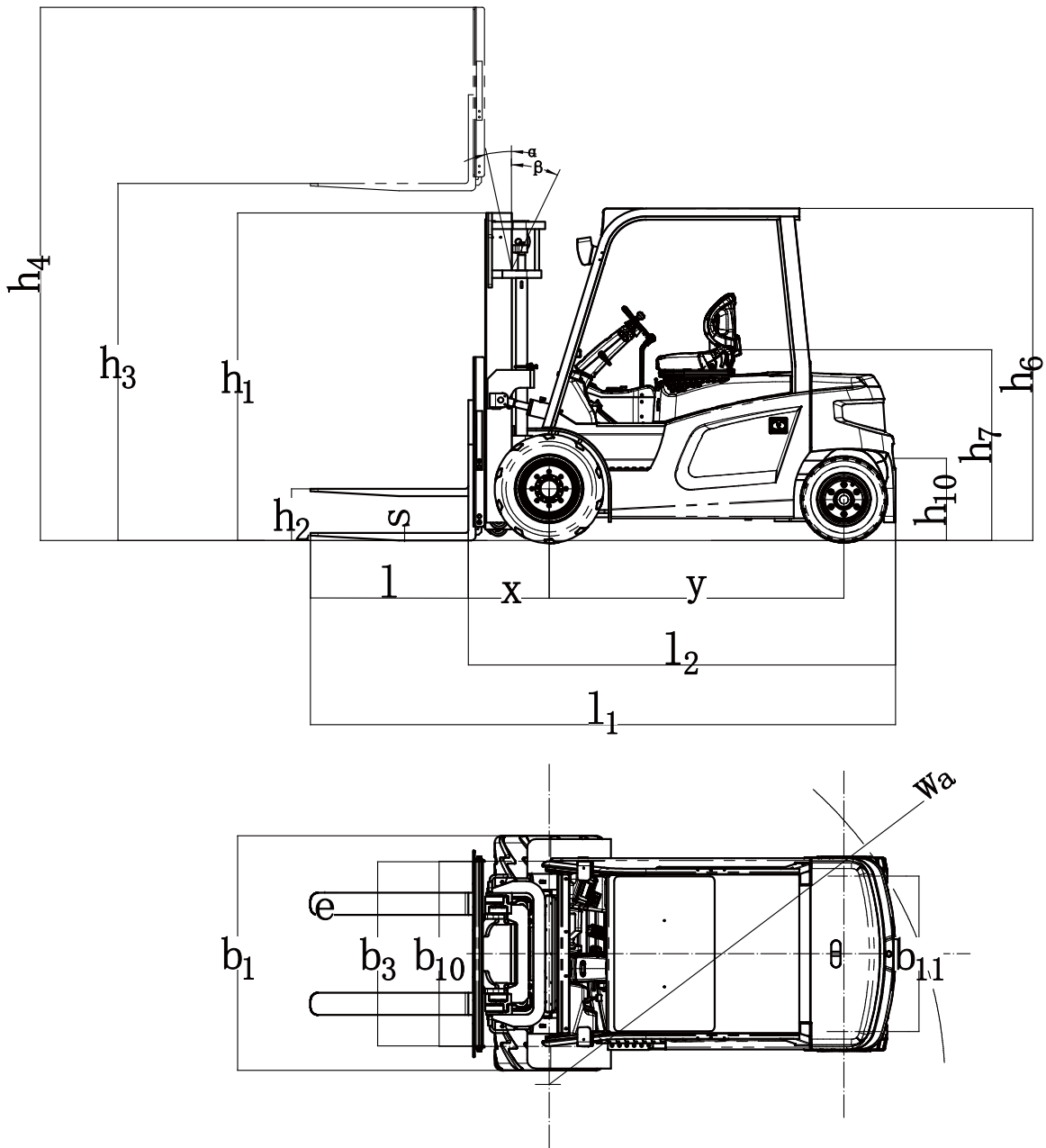
### 1.4.1 Performance data for standard truck

Distinguishing mark				
1.1	Manufacturer			
1.2	Model designation			CPD50L1
1.3	Drive unit			Electrics
1.4	Operator type			Seated
1.5	rated capacity	Q	kg	5000
1.6	Load center distance	c	mm	500
1.8	Load distance centre of drive axle to fork	x	mm	548
1.9	Wheelbase	y	mm	2000
Weight				
2.1	Service weight (include battery)		kg	7000
2.2	Axle loading, laden driving side/loading side		kg	10820/1180
2.3	Axle loading, unladen driving side/loading side		kg	3150/3850
Types,Chassis				
3.1	"Tyre type driving wheels/steering wheels"			Solid Rubber
3.2	Tyre size, driving wheels		mm	28x12.5-15

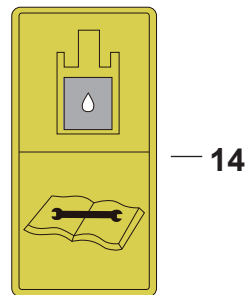
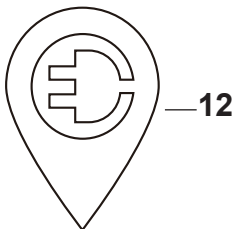
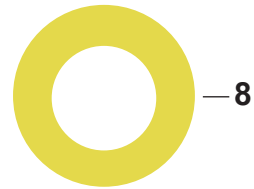
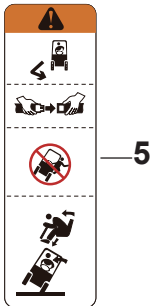
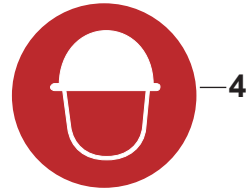
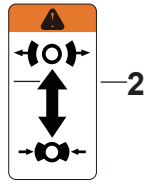
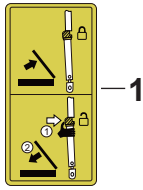
3.3	Tyre size, steering wheels		mm	23X10-12
3.5	Wheels, number driving/steering (x=drive wheels)		mm	2x/ 2
3.6	Tread, Driving wheels	b10	mm	1262
3.7	Tread, Steering wheels	b11	mm	1085
<b>Dimensions</b>				
4.1	Tilt of mast/fork carriage forward/backward	$\alpha/ \beta$ (°)		6/ 10
4.2	Height, mast lowered	h1		2230
4.3	Free lift (load backrest)	h2		150
4.4	Lift height	h3	mm	3000
4.5	Height, mast extended	h4	mm	4175
4.7	Height of overhead guard (cabin)	h6	mm	2250
4.8	Seat height	h7	mm	1208
4.12	Tow center of pin height	h10	mm	375
4.19	Overall length	l1	mm	3970
4.20	Length to face of forks	l2	mm	2900
4.21	Overall width	b1/ b2	mm	1550
4.22	Fork dimensions	s/ e/ l	mm	55X150X1070
4.23	Fork carriage class/type A, B			3A
4.24	Fork carriage width	b3	mm	1350
4.31	Ground clearance, laden, below mast	m1	mm	130
4.32	The minimum ground clearance of frame	m2	mm	150
4.34.1	Aisle width for pallets 1000 × 1200 crossways	Ast	mm	4440
4.34.2	Aisle width for pallets 800 × 1200 lengthways	Ast	mm	4640
4.35	Turning radius	Wa	mm	2675

Performance data				
5.1	Travel speed, laden/ unladen		km/h	16/18
5.2	Lifting speed, laden/ unladen		m/ s	0.3/0.46
5.3	Lowering speed, laden/ unladen		m/ s	0.45/ 0.51
5.5	Drawbar pull, laden/unladen		N	—
5.6	Max. drawbar pull, laden/unladen (time)			26000
5.8	Max. gradeability, laden/unladen		%	14/15
5.10	Service brake type			Hydraulicl
5.11	park brake type			Mechanical
Electric-engine				
6.1	Drive motor rating S2 60 min		kW	18
6.2	Lift motor rating at S3 15%		kW	25.4
6.4	Battery voltage/nominal capacity K5		V/ Ah	80V/560AH
6.5	Battery weight		lb.	530
Addition data				
8.1	Type of drive control			AC
10.5	Steering type			—
10.7	Sound pressure level at the driver's ear		dB (A)	70

### 1.4.2 Dimensions



### 1.5 Identification points



Item	Description
1	Gas spring indicator
2	Parking brake label
3	<b>Before operation:</b> <ul style="list-style-type: none"> <li>• Never climb the masts.</li> <li>• Never permit anyone to walk or stand under upraised forks or attachments.</li> <li>• Do not allow anyone to stand on the forks.</li> </ul>
4	Operators must wear a helmet before operation
5	<p>The stability of your truck is ensured if used properly and as intended. But once it tips over during unapproved applications or incorrect operation, always follow the instructions below:</p> <ul style="list-style-type: none"> <li>• Stay buckled up;</li> <li>• Don't jump;</li> <li>• Hold on tight;</li> <li>• Brace feet;</li> <li>• Lean away.</li> </ul>
6	Risk of serious injury or death due to entrapment. Never place your hands in between the inner and outer masts.
7	Read the "Instruction handbook"
8	Emergency stop switch
10	Bolt fastening
11	Use a hoist lift the truck via sling point. Sling point position see the sling point label of the truck. Please refer to our electronic version operation manual for during hoisting.
12	Charging indicator
13	<b>Real-time fleet data management</b> <ol style="list-style-type: none"> <li>1. SCAN QR code and Download App</li> <li>2. Register a new account</li> <li>3. Activate Bluetooth and connect the truck (The Bluetooth device name is the serial number of the display, which is shown on the display when turn on the power).</li> <li>4. Monitor battery status and truck location in real time</li> </ol>
14	"Fill Hydraulic fluid port" label

## 1.6 Truck data plate

For queries regarding the truck or ordering spare parts please quote the truck serial number.

Item	Description
1	PRODUCT NAME
2	MODEL TYPE
3	SERIAL NO.
4	MANUFACTURE DATE
5	UNLADEN MASS
6	UNLADEN MASS WITHOUT BATTERY
7	BATTERY VOLTAGE
8	RATED DRIVE POWER
9	MAX CAPACITY
10	MAX LIFT HEIGHT
11	RATED CAPACITY
12	LOAD CENTER
13	MAX BATTERY WEIGHT
14	MIN BATTERY WEIGHT

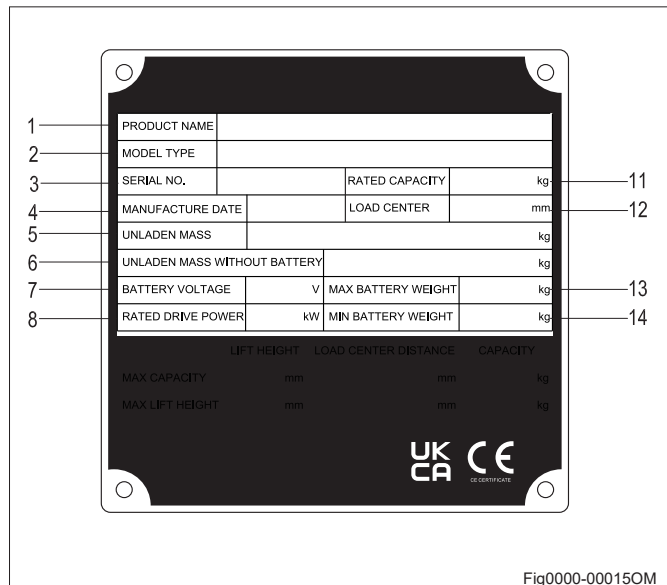


Fig0000-00015OM

## 1.7 The load capability chart

The capacity plate gives the capacity (Q) of the truck in kg for a vertical mast.

The maximum capacity is shown as a table with a given load centre of gravity D (in mm) and the required lift height H (in mm).

The capacity plate of the truck indicates the truck's capacity with the forks as originally supplied.

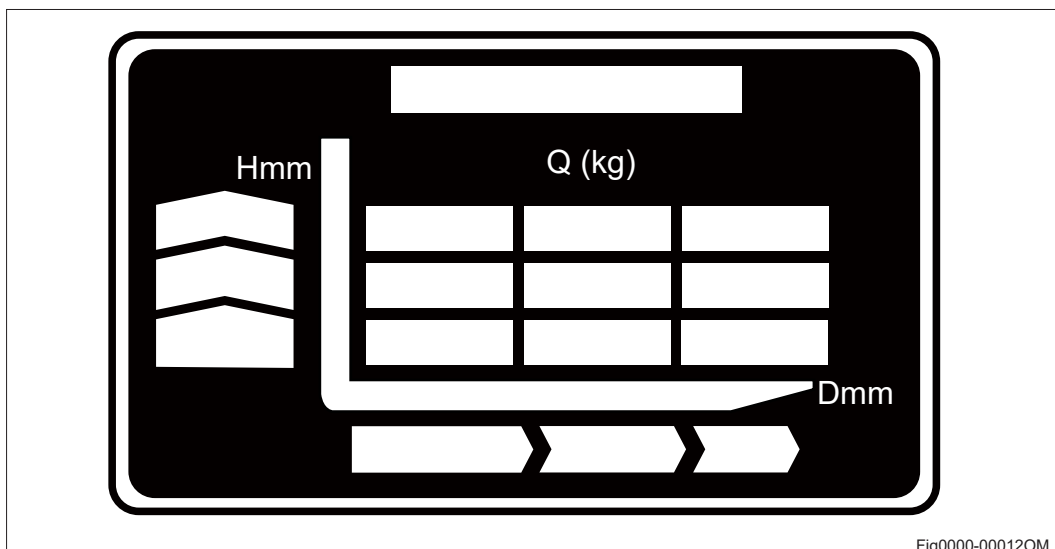


Fig0000-00012OM



## C Safety

### 1.1 Before Operation

Before using the truck, inspect the work area. It should be neat, well lit, adequately ventilated, and free from hazardous material. Aisles and roadways should be unobstructed and well marked. Operators must know the classification for the truck and use the truck only in permissible areas. Ensure that there are no loose objects on the truck or in the operator compartment, especially on the floor plate where they could interfere with pedal operation (if equipped) or foot room. Fire extinguishers and other emergency equipment should be visible and easy to reach. Wear safety equipment when required. Don't smoke in "No Smoking" areas, or while charging batteries or refueling combustion engine trucks. Never operate the truck with greasy hands. This will make the controls slippery and result in loss of truck control. Any questions or concerns about safety should be brought to the attention of a supervisor. If an accident should occur, it must be reported immediately.

### 1.2 Safety

#### **Safety Regulations For The Operation Of Forklift Trucks**

Operating safely is every operator's obligation and responsibility. The "Safety Instructions" cover basic safety procedures and warnings of general application to the forklift trucks. However, safety precautions given on the following pages are also applicable to lift trucks that have special specifications or attachments.

Read this manual carefully and become completely familiar with your truck to make sure the driver understands all the information, directives and safety guidelines that are applicable to your industrial truck are complied with.

#### **1. Know your truck sufficiently**

For the purpose of doing material handling job, the forklift truck is different from general passenger carrying vehicles in structure as follows:

View is partially obstructed due to the hoist system.

Rear wheel steering makes the rear of the truck swing outwards when going round corners.

Read the operator's manual and nameplates on the truck, and become familiar with your truck and operating procedures. If there is anything in the manual you do not understand, ask your service-partner to explain it to you.

#### **2. Operation permissions**

Only trained and authorized operator shall be permitted to operate the truck.

#### **3. Make periodic checks**

Inspect the truck at periodic intervals for oil leak, deformation, lousiness, etc. If neglected, short life of components will be caused and in the worst case a fatal accident would occur.

Make sure to replace "key safety parts" during periodic check.

Wipe off oil, grease or water from the floor, foot and hand levers, if any.

Strictly prohibit smoking, fire and spark nearby the battery when checking it.

If maintenance is performed on high position, such as mast, front and rear lamp, please be careful of falling off or being clamped.

Be careful not to be scalded when inspect the motor, controller etc.

#### **4. Stop using the forklift when it malfunctions**

Whenever malfunctions arise, you must stop the forklift, hang a sign of "danger" or "malfunction" and take off the key, then report the malfunction immediately.

only after the malfunction is eliminated, you may use the forklift.

## **5. Protect yourself**

Operator must wear helmet, safety shoes and work(protective) clothes, whenever you operate and maintain the truck, handle the consumables etc.

## **6. Prevent explosion**

Because there will be explosive gas in the bosom of the battery, prohibit any flame or sparks nearby it strictly.

Don't let any metal tools contact the terminals of the battery to avoid sparks or short circuit.

## **7. Working condition**

Make sure to operate the truck on fairly stable and even road surface.

If there is snow, ice accretion, or other obstacles, clean it before you operate the truck, or the truck may be out of control and even cause safety accidents.

Truck cannot be operated in potentially explosive atmosphere.

## **8. Tilting safely**

Don't tilt the mast with load high

Use minimum forward and reverse tilt angle when stacking and unstacking loads. Never tilt forward unless load is slightly above the stack or at low lift height.

When stacking loads on a high place, make the mast vertical at a height of 15 to 20 cm above the ground and then lift the load. Never attempt to tilt the mast beyond vertical when the load is raised high.

To unstack loads from a high place, insert forks into the pallet, lift slightly and drive backwards, then lower the load. Tilt the mast backwards after lowering. Never attempt to tilt the mast with the load raised high.

## **9. To handle bulky, long loads**

When handling bulky loads, which restrict your vision, operate the machine in reverse or have a guide to help you, and when you are guided, make sure you understand the meaning of the guide's gesture, flag, whistle or other signals.

When operating with long loads such as lumber, pipe, etc., or in the case of the Large-sized model or the truck with spreader(load or truck with a stretched-out attachment), be extremely careful of load at corners or in narrow aisles. Be alert for fellow workers.

## **10. Start safely**

Before starting up(starting the truck), make sure that:

Your safety belt is fastened;

The vehicle doors is closed tightly.

The parking brake lever is applied securely(released).

The travel switch is in neutral.

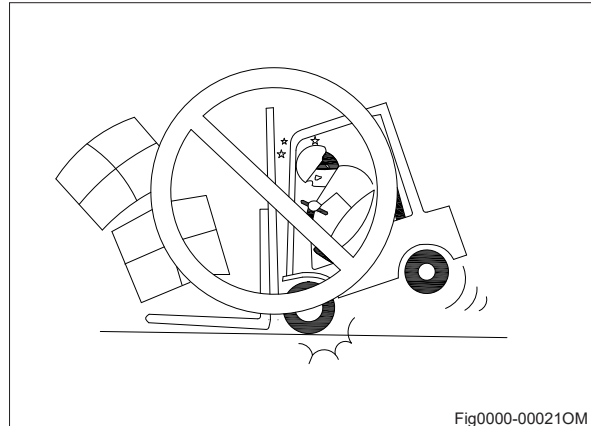
No one is under, on and close to(in the vicinity of) the truck.

Don't step(depress) the accelerate pedal or control(operate) the lifting lever or tilting lever before turning on the power.

Start slowly and never travel at excessive speed.

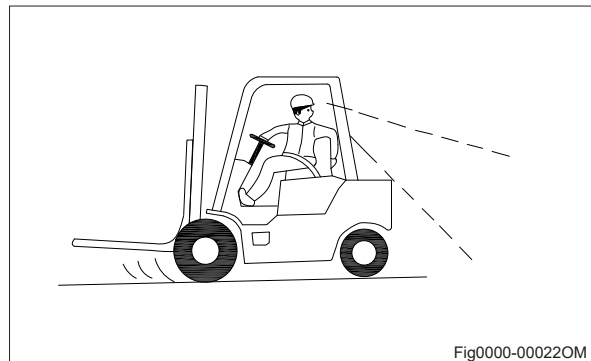
### 11. Prohibit sudden stops, starts or sharp turns

Operate the controls smoothly. Avoid sudden stops, starts or sharp turns. It is dangerous to make a sudden brake. for it may cause the truck to overturn.



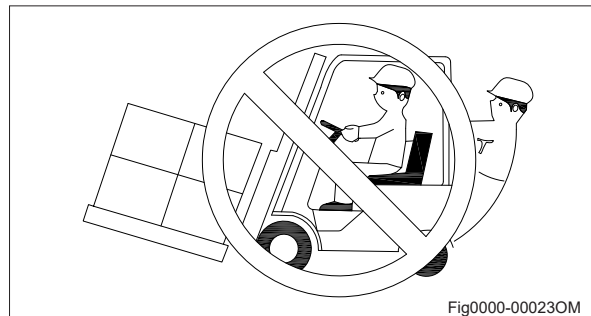
### 12. Focus on the travelling route

Pay attention to the route of the truck, be sure to keep a clear view of it and look in the direction of travelling.



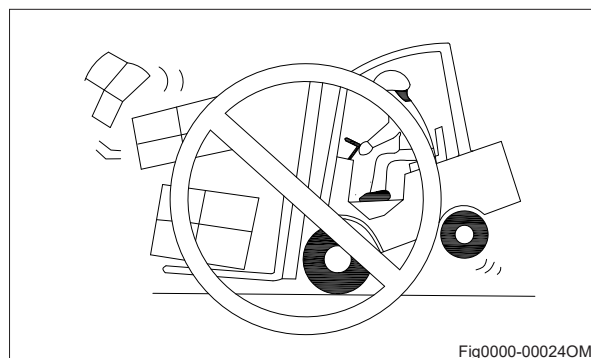
### 13. Don't offer rides to others

Other person is not allowed to get on the fork, tray or forklift. Do not use people as an additional counterweight.



### 14. Carry the loads in a proper manner

- Taking account of the shape and material of loads to be handled, use a proper attachment and tools.
- Avoid hoisting the load with wire rope suspended from the forks or attachment, since the wire rope may slide off. If needed, a qualified personnel (should perform the slinging), making use of a hook or crane arm attachment.
- Take care not to protrude the forks out of the load. The protruded fork tips may damage or turn over/bump the adjacent load.
- Be careful not to let the forks touch the floor, so as to avoid damaging the fork tips or driving surface.



### 15. Concentrating on your work

Keep your mind on your work. Learn to estimate danger before it arises.

### 16. Mount and dismount properly

Never mount or dismount the moving truck. Use the safety steps and safety handgrip and face the truck when mounting or dismounting the truck. Don't jump!

### 17. Never operate the truck unless the operator is properly seated

Before starting the truck, adjust the seat so you can get easy access to all hand and foot controls.

### 18. Know the capacity of your truck

Know the rated capacity of your lift truck and its attachments, and never exceed it. Do not use a man as an additional counterweight. It's quite dangerous.

### 19. Be seated safely

Keep your head, hands, arms, feet and legs within the confines (cab) of the operator's compartment (truck). Never (stick your hands or any other parts of your body out of it) for any reason.

### 20. Use proper attachments

We afford all types of attachments, such as rotating roll clamp, bale clamp, side shifter, and crane jib. You should refit the truck under our license if you want (Modifications to the truck must be authorized by the manufacturer). Only specialists are permitted to fit the attachments and connect the energy supply for power-driven attachments.

It is forbidden to refit the truck by yourself.

### 21. Driving over a dock-board or bridge-plate

Before driving over a dock-board or bridge-plate, be sure that it is properly secured and strong enough to sustain the weight.

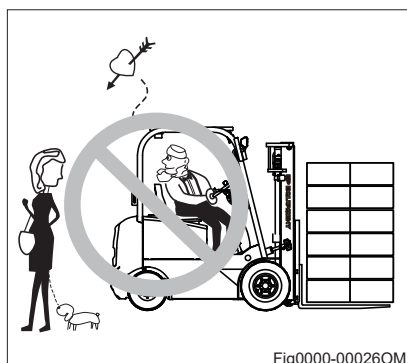


Fig0000-00026OM

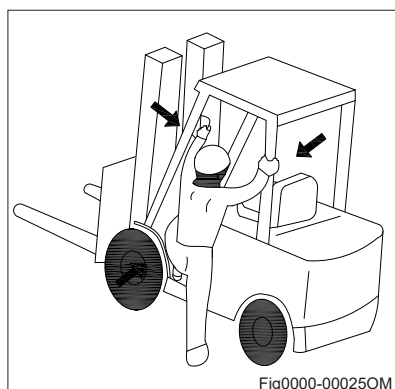


Fig0000-00025OM

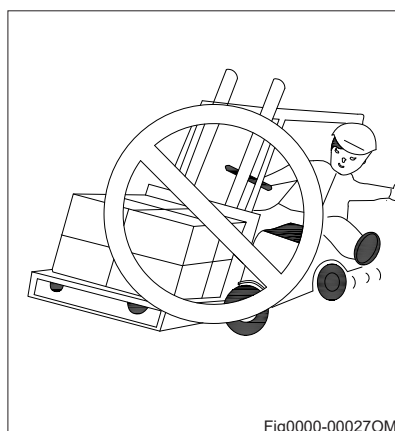


Fig0000-00027OM

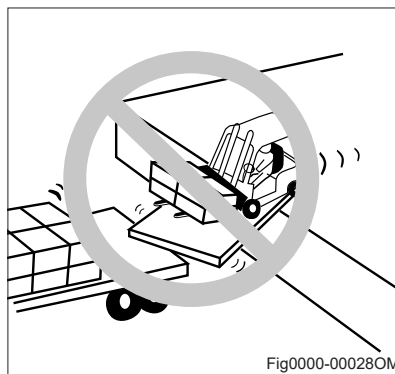


Fig0000-00028OM

**22. Overhead guard and load backrest**

Safeguard protect you not to be hurt by the goods fallen. Load backrest can keep the load stable. It is forbidden to use truck without overhead guard or load backrest.

Any additional bores or welding to the overhead guard on the overhead guard will compromise its rigidity. It is therefore strictly prohibited to drill holes in the overhead guard or to weld to it.

**23. Never climb the masts.**

It is forbidden to stand or walk under the upraised fork or the attachments.

It is also forbidden to walk up the or stand on the forks.

**24. Avoid being clamped by the mast**

It is forbidden to put your hands, arms or head between the mast and overhead guard.

It is forbidden to put your hands between inner and outer masts.

**25. No off-center loads**

The goods is easy to drop when turning or passing rough road for off-center loads. And the forklift may topple over more probably.

**26. Don't stack load too high on forks**

Don't stack loads on forks in such a way that the top of loads exceeds the load backrest height. If unavoidable, make the load stable securely. When handling bulky loads that restrict your vision operate the truck in reverse or have a guide.



Fig0000-00029OM

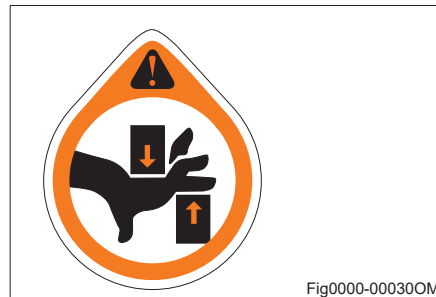


Fig0000-00030OM

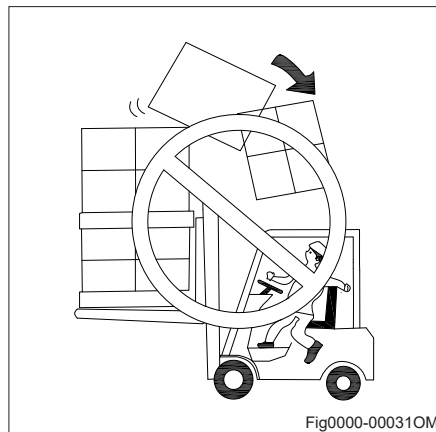


Fig0000-00031OM

### 27. Tilt backwards when loaded

Travel with load as low as possible and tilt back. If operating with steel pallet or the like, be sure to tilt back the mast to prevent it from slipping off the forks.

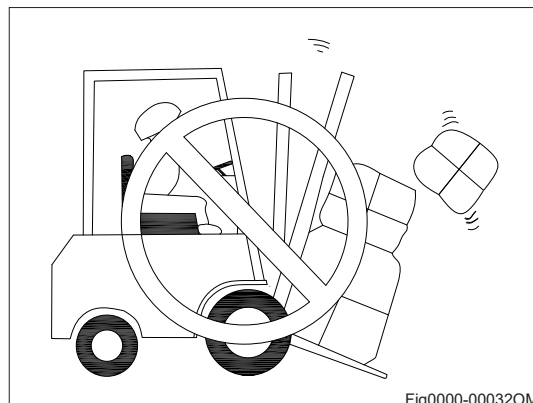


Fig0000-00032OM

### 28. Watch for doorways and slow down at corners

Watch for branches, cables, doorways, or overhangs. Be cautious when working in congested areas.

Slow down and sound the horn at the entrances and exits of the aisles and other locations where vision is restricted.

When make a turn, be sure the speed of the truck is lower than the 1/3 of the max. allowable speed.

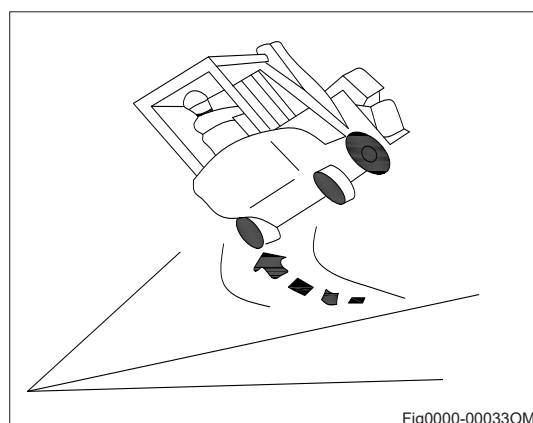


Fig0000-00033OM

### 29. Keep some distance from the roadside and the kerb

### 30. Do not turn or travel in a horizontal direction when moving up a ramp in case of toppling over.

When operating loaded truck, have the rear end of your machine pointing downhill.

When operating unloaded truck, have the rear end of your machine pointing uphill.

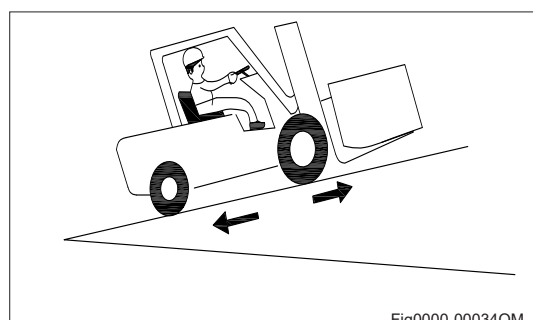


Fig0000-00034OM

31. After the protective device like overhead guard and mast load bracket is dismantled, it is prohibited to operate the truck or carry loads.

### 32. Ensure adequate lighting

The industrial truck working area must be adequately lit. Turn on the headlamps and lights when working in the dark area to make sure the operator can see clearly.

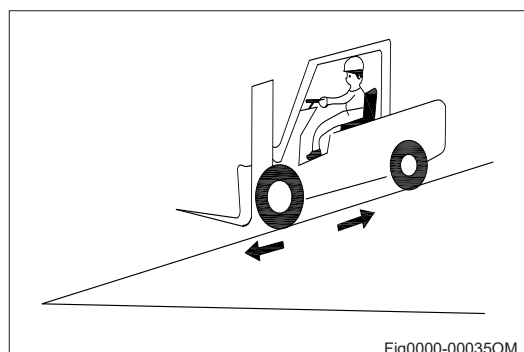


Fig0000-00035OM

In the case of tip-over

The stability of your truck is ensured if used properly and as intended. But once it tips over during unapproved applications or incorrect operation, always follow the instructions below:

- Stay buckled up;
- Don't jump;
- Hold on tight;
- Brace feet;
- Lean away.

**33. Avoid the following possible instability related to loads:**

- Loads are protruding to the side;
- Loads are too wide;
- Loads are too high;
- Loads exceed the capacity.
- The load is liquid, and its center of mass inside the container may shift due to inertial force such as pulling away, braking or turning.
- Loads are not homogeneous;
- Loads are off-center;
- Loads are not arranged properly or fastened tightly.
- Loads are swinging while operating;
- Loads are raised high while travelling;
- Loads are on the downhill side while driving on gradients.
- Loads are higher than the backrest while tilting.

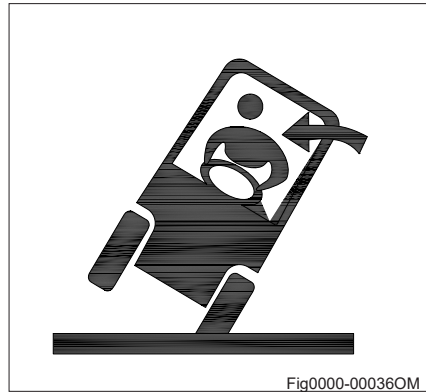
**34.** Small loads should be carried on a pallet and not placed directly on the forks.

**35. Avoid lifting loads on a grade**

Never lift loads with the truck inclined. Avoid loading and unloading on a grade.

**36. Never lift a load over anyone**

Never permit anyone to stand on or walk under upraised forks or other attachments if equipped. If unavoidable, use a safety stand or block to prevent a possibility of fork attachments falling down or moving unexpectedly.



### **37. Check the ground of the work area**

Inspect the surface over which you will run. Look for holes, drop-offs, obstacles, and protrusions. Look for anything that might cause you the truck to lose control, or jolt.

Clear away trash and debris. Pick up anything that might puncture a tire or let the load lose balance.

Slow down for wet and slippery roads.

Stay away from the edge of the road.

Do not drive the truck up or down steps.

If the ground is bumpy, it will cause the truck jolt and bring much noise.

Do not operate the truck when the weather is execrable, such as windy, thunder storm, snow and etc. Especially when wind speed is higher than 10m/s, don't operate the truck outdoors.

### **38. Carry the load low**

It is dangerous to travel with forks higher than appropriate position regardless of whether loaded or not. Keep the good traveling posture. (When traveling, the forks should be 15 to 30 cm above the ground or floor, and the mast should be tilted backwards. )

Do not operate the side shift mechanism, if equipped, when the forks are raised and loaded, this will cause the truck to be unbalanced.

### **39. Fire extinguishers**

The workplace should be equipped with fire extinguishers. Users can also select a vehicle equipped with fire extinguisher which is usually placed on the frame.

Make sure operators know the fire extinguisher's location and are familiar with how to use it in an emergency situation. Relevant handling information is provided on the fire extinguisher.

### **40. Hydraulic system risks**

Hydraulic system is under pressure, whenever take out the inspection or maintenance, be aware of the risk of injury, wear protective equipment.

Before connecting hydraulic lines or hydraulic couplings, the hydraulic system must be depressurized.

### **41. Residual risks**

In spite of careful work and compliance with all applicable and regulations, the possibility of other dangers when using the industrial truck cannot be entirely excluded.

Residual dangers can include:

- Escape of consumables due to leakages or the rupture of lines, hoses or containers;
- Risks of accident when driving over uneven ground, wet, icy or greasy ground, gradients, irregular surfaces, or with poor visibility;
- Risks of fire and explosion due to the battery and electrical voltage;
- Risk caused by insufficient maintenance or testing;
- Risk caused by using the wrong consumables;
- Disregarding the safety regulations.

### **42. Braking distance**

Taking into account the specified minimum braking distance, do not use the truck on a long slope with a gradient of more than 15%. If you need to use the truck on slopes with higher gradients, please first consult your dealer. The gradabilities given in the type sheet are calculated based on the truck's traction and are only applicable to situations in which the truck must surmount small obstacles or when driving on fairly even road surfaces.



### 1.3 Battery Safety



#### **WARNING**

*Batteries contain dissolved sulfuric acid, which is poisonous and caustic. Batteries also can produce explosive gases.*

Remain aware of the following information.

- Remove any metal rings, bracelets, bands, or other jewelry before working with or near batteries or electrical components.
- Never expose batteries to open flame or sparks.
- Shorting of battery terminals can cause burns, electrical shock, or explosion. Do not allow metal parts to contact the top surface of the battery. Make sure all terminal caps are in place and in good condition.
- Batteries may only be charged, serviced, or changed by properly trained personnel. Always follow all instructions provided by the manufacturers of the battery, charger, and trucks.

### 1.4 Related Safety Instruction and Standard(For CE)

The design and manufacture of electrical element comply with the low voltage standard 2006/95/EC.

#### **Noise emission level**

CPD50L1: 70 dB(A)

Noise will be according with EN12053:2001 and 2000/14/EC.

Sound pressure level on the operator's position is lower than 75dB(A), measurement uncertainty is 1.5dB(A).

#### **Vibration and acceleration**

Vibration parameters are measured according to standards of ISO5349-2:2001, EN13059:2002, ISO2631-1:1997, and the result meets the requirement of 2002/44/EC. Whole body vibration is lower than 1.1m/s<sup>2</sup>.

#### **Electrical requirements**

The manufacturer certifies compliance with the requirements for the design and manufacture of electrical equipment, according to EN 1175 "Industrial Truck Safety - Electrical Requirements", provided the truck is used according to its purpose.

## EMC-Electromagnetic compatibility

Electromagnetic compatibility (EMC) is a key quality feature of the truck.

EMC involves

- limiting the emission of electromagnetic interference to a level that ensures the troublefree operation of other equipment in the environment.
- Ensuring sufficient resistance to external electromagnetic interference so as to guarantee proper operation at the planned usage location under the electromagnetic interference conditions to be expected there An EMC test thus firstly measures the electromagnetic interference emitted by the truck and secondly checks it for sufficient resistance to electromagnetic interference with reference to the planned usage location . A number of electrical measures are taken to ensure the electromagnetic compatibility of the truck.
- Our truck has been successfully tested according to EN12895 as well as the standardized instruction contained there in.



### CAUTION

*The EMC regulations for the truck must be observed.*

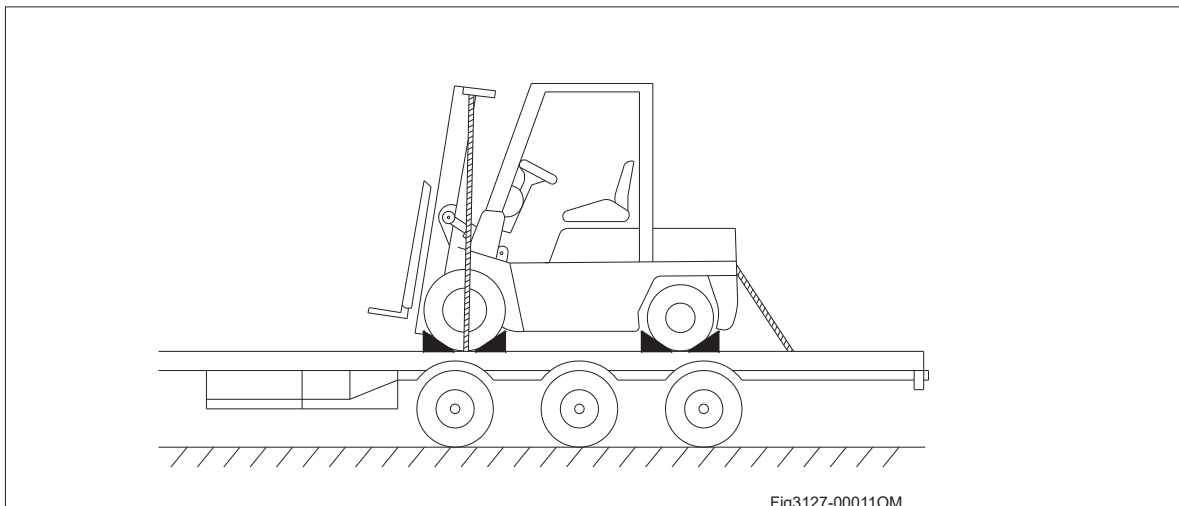
*When replacing truck components for repair the protective EMC components must be installed and connected again.*

## D Transport and Commissioning

### 1.1 Transport

Forklift trucks are generally used for loading, unloading and short-distance transportation. They are not designed to be a long-distance mode of transport. A forklift that needs to be transported over a long distance should be transported in a ship, train or a truck having a load capacity over 13T.

- Park the forklift on the lorry or trailer and Lower the lift mast.
- Apply the parking brake pedal.
- Secure the front wheels and rear wheels with chocks to prevent slipping.
- To lash the forklift truck with a lifting mast installed use the holes on the top cross beam of the mast and the trailer coupling pin.
- The truck can now be transported.

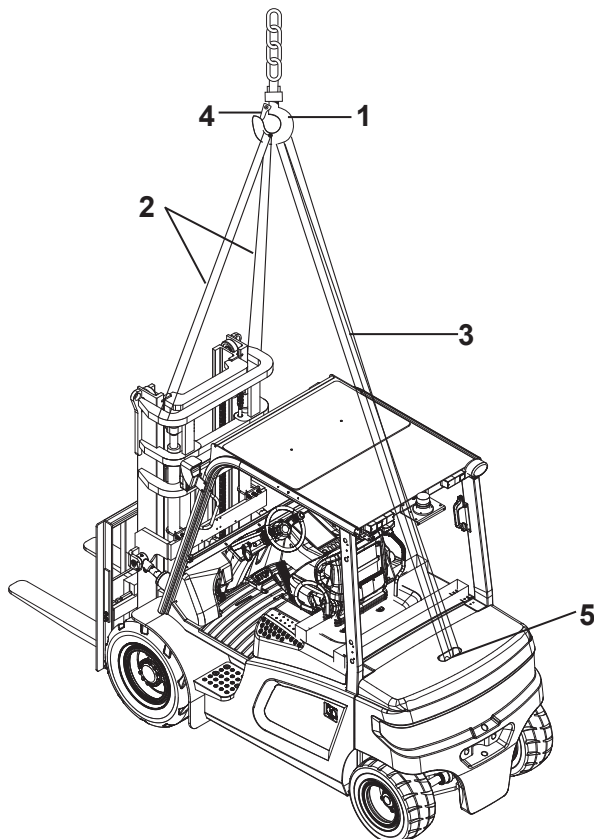


#### **WARNING**

- *If the truck is to be transported without a mast, it must be tied at the front overhead guard.*
- *When fixing forklift, take effective measures according to specific condition to guarantee the safety of transportation.*
- *Correctly fix the forklift when transporting by lorry or trailer.*
- *Chock the forklift to avoid accident movement.*
- *Only use tension belt with big enough nominal strength or fasten the belt to fix the truck.*

## 1.2 Use a hoist to lift the truck

- Securely fasten wire ropes (3) fastening point (5).
- Securely fasten wire ropes (2) to the lifting holes in both ends of the outer mast crossbar.
- Hang all sling ends on the lifting hook (1) of the hoist.



### **i** NOTE

*The wire rope fastened to the counterweight end must pass through the gap in the overhead guard, without putting stress on the overhead guard.*



### **WARNING**

- Ensure that no one is in the working area of the hoist when using it to lift the truck!
- Walking around under the lifted load is absolutely prohibited.
- Fully tilt the mast backward when lifting.
- When assembling lifting tool, notice that the lifting tool will not touch forklift part or overhead guard when lifting.
- Do not lift a forklift by its cab frame (overhead guard).



### **CAUTION**

- After hanging the sling on the lifting hook, the safety lock (4) must be fastened.
- Only use lifting gear with sufficient capacity (Weight lifted = net weight + battery weight; see truck nameplate).
- The sling must be fastened at the designated lifting points when using the hoist.

➤ **Towing regulations**

When the truck needs to be moved, a tow rope or rod can be attached to the towing bar (6). A tow rope can also be attached to the base of the lift mast.



**CAUTION**

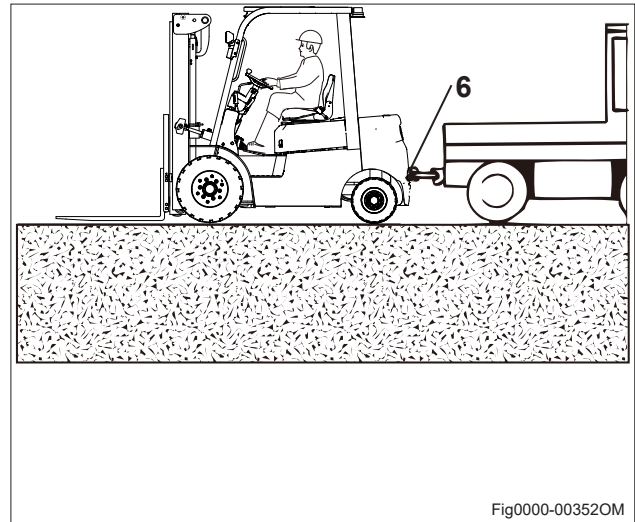
*Braking can only be performed by the brake pedal or parking brake during towing.*

➤ **Towing procedure**

You can tow the forklift to the safe place with towing bar(6) when the forklift can't run.

Don't tow the truck of which its steering system or brake system has been damaged.

- Place the travel combination switch in neutral;
- Lower the goods, but do not allow the fork arms to touch the ground.
- Apply the parking brake.
- Switch off the key switch.
- Disconnect the battery connector if necessary.
- Check the tractive and braking forces of the towing vehicle.
- With the help of a guide, manoeuvre the towing vehicle to the truck.
- Secure the towing bar(6) to the tow coupling on the towing vehicle and on the truck.
- Sit in the driver's seat of the truck being towed and fasten the seat belt.
- Release the parking brake.
- Tow the truck.
- After towing, secure the truck so that it cannot roll away (e.g. by applying the parking brake or by using wheel chocks).
- Disconnect the wire rope to the towing bar.



**i** **NOTE**

*The driver should operate the steering wheel during towing, and the brake when necessary.*



## DANGER

*If the towing vehicle brakes, there is a risk that the truck will drive into the towing vehicle!*

*If a rigid connection has not been used for power transmission in two directions during towing, the truck may drive into the towing vehicle when the towing vehicle brakes. Use a tested tow bar for safety reasons.*

*Use a tested tow bar.*

### 1.3 The structure and stability of truck

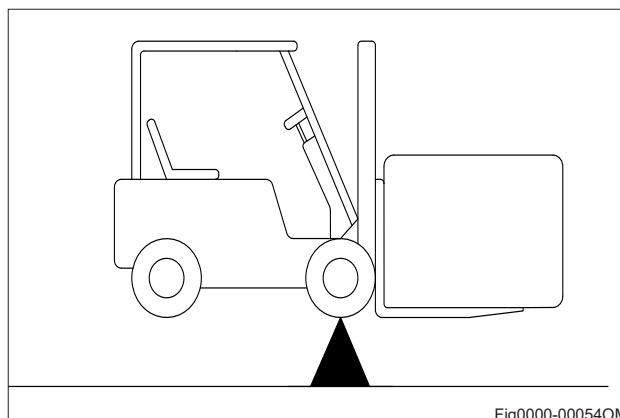
Prevent the forklift to tip over! It is very important for operator to know the truck's structure and relationship between load and stability.



## WARNING

### The structure of the truck

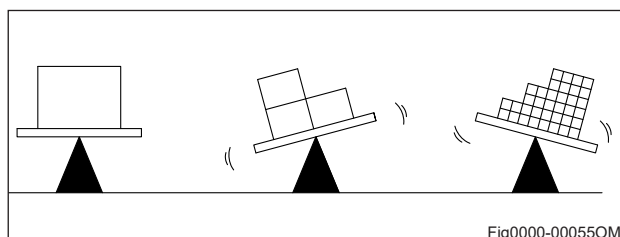
- *The basic structure of the truck is mast (include mast and forks) and body (include tire)*
- *The lift truck keeps the balance of weight between the truck body and the load on the forks with the center of the front wheels as a fulcrum when the rated capacity load is placed in position.*
- *Due care should be paid to the gravity center of loads and forklift to maintain the stability of the truck.*



## WARNING

### Load center

*There is difference in gravity because of the loads' shape, such as box, board and large roller. It is very important to distinguish the difference of the gravity center of loads for evaluating the truck's stability.*



### ➤ Wind loads

Wind forces can affect the stability of a truck when lifting, lowering and transporting loads with large surface areas .

Light loads must be especially secured when they are subjected to wind forces. This will prevent the load from sliding or falling.

Stop the truck in both cases .



**WARNING**

**Gravity center and stability**

The combined gravity center that is composed of the forklift center and the load gravity center determine the stability of lift trucks.

When unloaded, the barycenter does not change;  
 when loaded, the barycenter is determined by the truck and the load's center.  
 The barycenter is also determined by the tilting and lifting of the mast.  
 The combined center is determined by these factors:

- Load's size, weight and shape
- The lifting height
- The tilting angle
- The acceleration
- The radius of turning
- The road and grade's angle
- The attachments

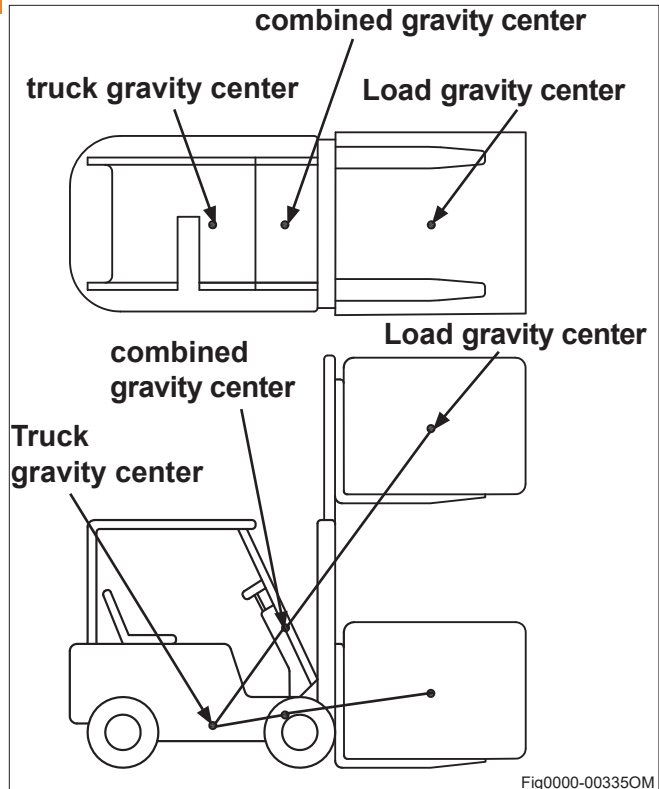


Fig0000-00335OM



**WARNING**

*In order to make the truck stable, the combined center must be in the triangle which is made up of two points that the two front wheels attach ground and the midpoint of the back axle.  
 If the combined center is in the front driving axle, the two front wheels become two fulcrums, the truck will overturn.  
 If the combined center departs the triangle, the trucks shall overturn in the corresponding direction.*

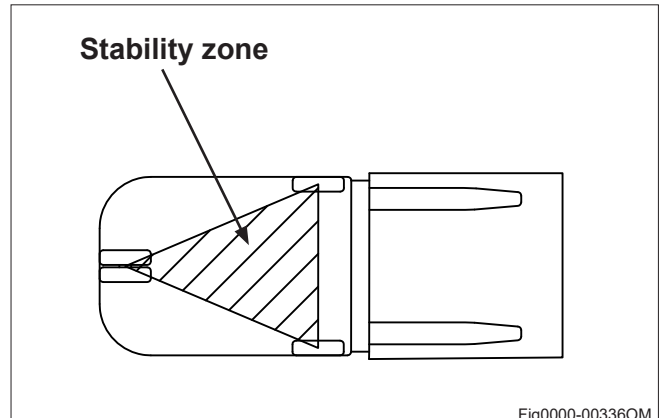


Fig0000-00336OM

## 1.4 Commissioning

Using the truck for the first time

Only operate the truck with battery current.

Preparing the truck for operation after delivery or transport.

Procedure:

- Check whether is complete.
- Fully charge the battery (See Chapter F, Section1.2).

The truck can now be put into operation(See Chapter E,Section1.1).

### **i** NOTE

Commissioning and driver instruction must only be performance by trained personnel. If several trucks are supplied, make sure that only load lifting devices, masts and basic trucks with the same serial number are assembled.

## 1.5 During running-in

- We recommended operating the machine under light load conditions for the first stage of operation to get the most from it. Especially the requirements given below should be observed while the machine is in a stage of 100 hours of operation.
- Must prevent the new battery from over discharging when early used. Please charge when remain power is less than 20%.
- Perform specified preventive maintenance services carefully and completely.
- Avoid sudden stop, starts or turns.
- Oil changes and lubrication are recommended to do earlier than specified.
- Carry only 70-80% of the rated load.



---

## E Operation

### 1.1 Checks and operations to be performed before starting daily work

- Visually inspect the entire truck (in particular wheels) for obvious damage.
- Visually inspect the battery attachment and cable connections.
- Check the mast, load backrest and forks for visible damage such as cracks.
- Check wheels for wear and damage.
- Test the warning device.
- Make sure the load chains are evenly tensioned.
- Check all the devices for normal functions.
- Check the condition and function of the driver's seat and seat belt.
- Check the entire truck as well as the surface beneath it for signs of fluid leakage.
- Check the oil level in the oil tank of the working and steering hydraulic systems.
- Check battery connector.
- Check decal condition.
- Check the tyres.
- Test brake system (parking brake and service brake).
- Test the emergency stop switch.
- Check display/battery discharge indicator.
- Test working lights.
- Check forward and reverse functions.
- Test horn.
- Test the lift/lower, tilt and if applicable the attachment hydraulic control functions.
- Test steering.
- Adjust the visibility aid equipment (mirrors, camera systems etc.) so that the working environment can be clearly seen.



#### **WARNING**

*Never start the truck before any damage or failure to the truck has been settled.*

#### 1.1.1 Switching on the truck

- Slightly rotate and Pull up emergency stop button.
- Before starting the forklift, place the direction lever in neutral;
- Insert the key in the key switch and turn it clockwise
- Test the brake pedal and parking brake.
- The display shows the remaining state of charge percentage.  
The truck is now ready for operation.



#### **WARNING**

*Please do not open the rear window if the truck is equipped with cab when driving, to avoid the risk of broken glass.*

## 1.2 Driving, Steering, Braking

### ➤ Driving

#### Procedures

- Tilt the mast back: Operate the lift lever, raise the forks 15~20cm off the ground. Operate tilt lever and tilt the mast back to the end.
- Turn the combination switch: Push the combination switch forward, truck goes forward; pull the combination switch backward, truck reverses.
- Hold steering wheel with left hand, lean on the steering wheel with right hand, step on the accelerator pedal with right foot slightly, and then the truck travels.



#### **WARNING**

*The distance from the driver's head to the overhead guard has been reduced in certain manufacturer forklift trucks (such as the container overhead guard, etc.). Only drivers where the distance from the driver's head to the overhead guard exceeds 30 mm are permitted to operate this kind of forklift truck.*



#### **WARNING**

*For trucks with cab, the doors must be closed before driving the truck.*

### ➤ Steering

A forklift is not like an ordinary vehicle, and it is rear-wheel steered, which means that the rear counterweight swings outward when turning. Decelerate when steering. Move the steering wheel counterclockwise, the truck turns left; move the steering wheel clockwise, the truck turns right.

### ➤ Braking

Braking ways have service brake and parking brake.

Service brake: Step on the brake pedal to decelerate or stop.

Parking brake: In order to avoid accident move of the forklift, apply the parking brake pedal, make sure press emergency stop switch after stop.



#### **WARNING**

*Never adopt parking brake instead of service brake in normal travelling.*

*Emergency stop is unavoidable in travel, only when the service brake is out of control can apply the foot(parking) brake pedal to stop the truck.*

*Be careful when braking and avoid loads sliding.*

### ➤ Parking

Procedures:

- Decelerate, then depress the brake pedal until the vehicle stops.
- Get the combination switch in neutral.
- Press the emergency stop switch to avoid truck move.
- Lower the mast to the floor and tilt the mast all the way forward.
- Turn the key switch to stop the forklift, remove the key and keep it in a secure place.
- Press the emergency stop switch to shut down the power.



## WARNING

An unsecured truck may cause accidents. The truck wheels may need to be secured with wedges.

Never park the truck on the travelling route to influence other truck travelling.

The truck must be parked in a frost-free, clean, dry location and 0-40°C condition. Parking the forklift in an environment below 0 ° C for a long time is forbidden.

### 1.3 Loading

#### ➤ Adjusting the fork spacing

- Toggle the fork positioning lock;
- Move the forks, spacing them according to the size of the goods to be lifted.
- The forks should be spaced as far apart as possible under the load for stability. Note that the two forks should be equal distance from the centerline of the forklift truck.
- Insert the positioning lock into the notch.

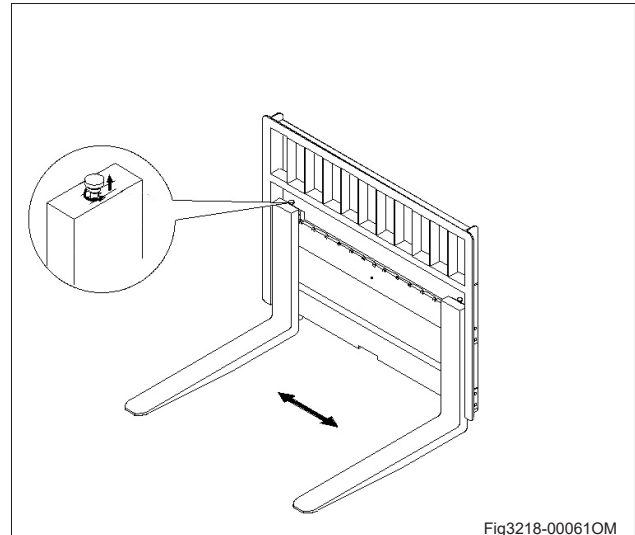


Fig3218-00061OM



#### NOTE

The centre of gravity of the goods should be at the centre of the fork arms.



#### CAUTION

Loads should be arranged so they do not project past the edge of the trucks loading surface.

Do not handle loads that are taller than the load backrest unless the load is secured to prevent it from falling off or backward onto the truck.

#### ➤ Lifting loads

- Carefully approach the load to be lifted.
- Apply the service brake .
- Set the mast vertical.
- Raise the forks to the correct height for the load.
- The forks should be spread as far apart as possible underneath the load.
- Drive the truck forward and insert the fork arms beneath the goods, making sure the goods are leaning against the vertical section of the fork arm and that they are not touching adjacent goods.

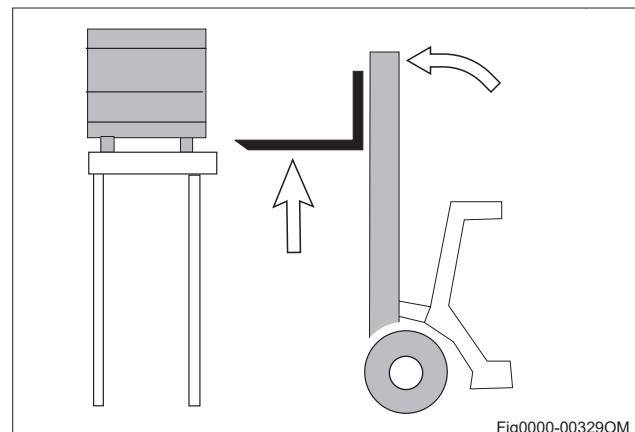


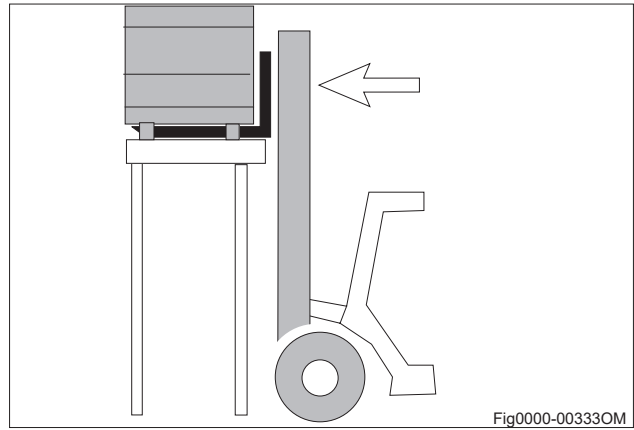
Fig0000-00329OM



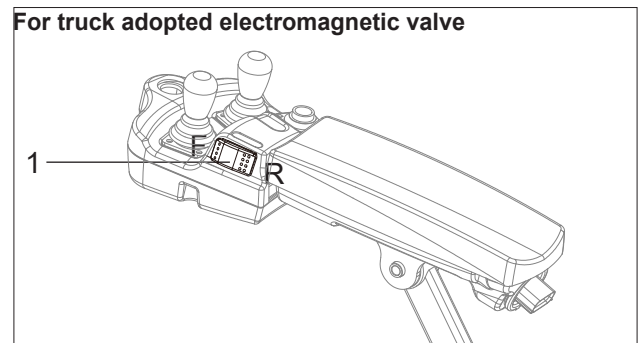
#### NOTE

At least two thirds of their length must extend into the load.

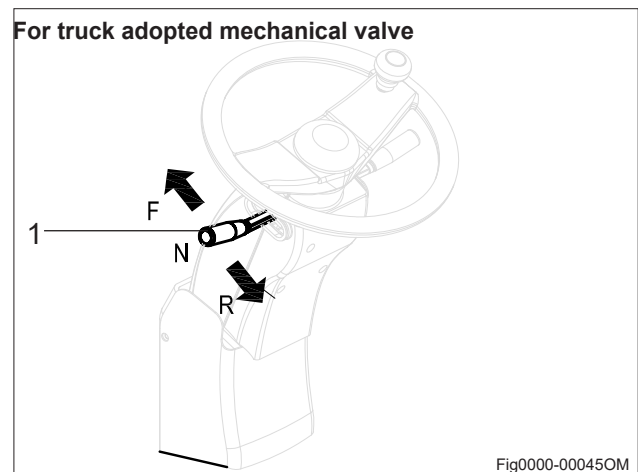
- Raise the fork carriage until the load rests freely on the forks.



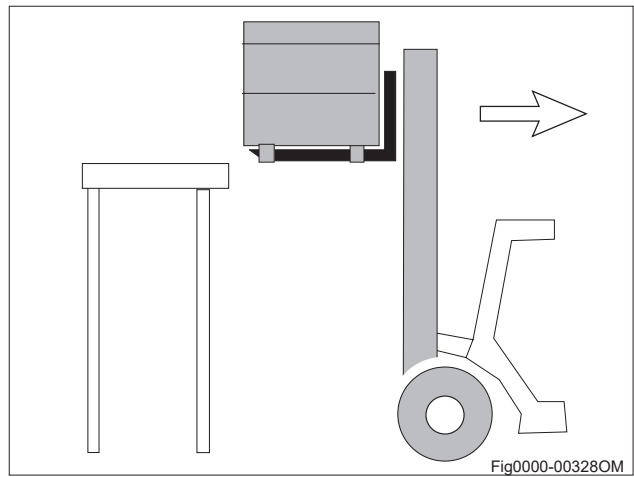
- Set the travel combination direction switch (1) to reverse and release the service brake.



- Reverse carefully and slowly until the load is outside the storage area.



- Tilt the mast back.



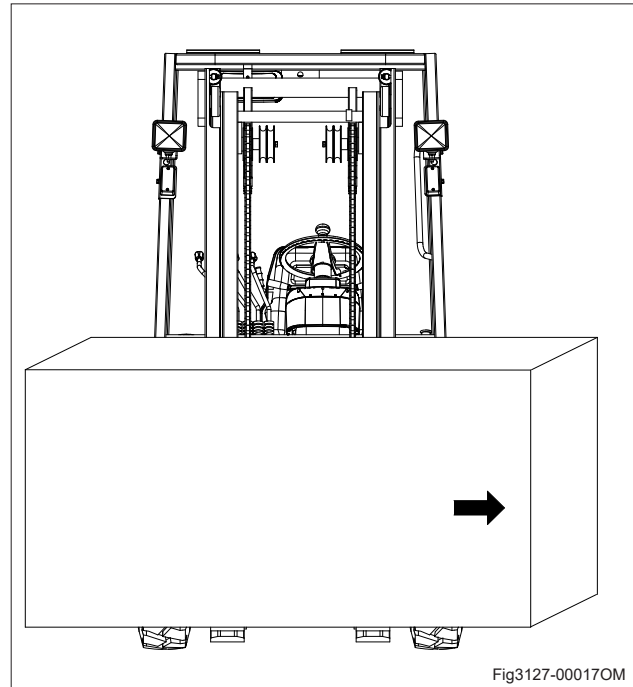
### ➤ Transport loads

- When transporting goods, the load should be as close to the ground as possible with the lift mast tilted back, and must be centered within the mast.
- The truck absolutely must not turn or travel in a horizontal direction when moving up a ramp.
- Gently accelerate with the accelerator pedal and slowly brake with the brake pedal. Be ready to brake at all times.
- Adapt your travel speed to the conditions of the route and the load you are transporting.
- Watch out for other traffic at crossings and passageways.
- Always travel with a lookout at blind spots.

If the load is stacked so high that it affects forward visibility, then reverse.

### ➤ Depositing loads

- Drive the truck carefully up to the load handler.
- Lift the fork carriage to a suitable height.
- Place the lift mast in a vertical position.
- Proceed to where goods are to be placed.
- Slowly lower the goods until the fork arms can separate from the goods.
- Reverse the truck.



## 1.5 Driving on ascending and descending gradients



### **DANGER**

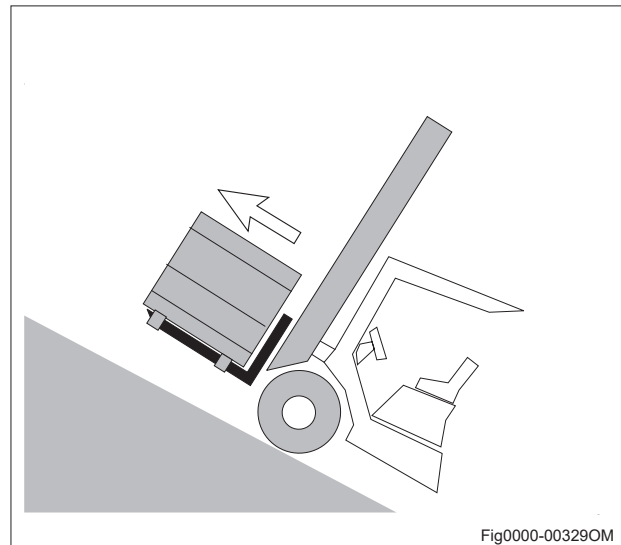
*Danger to life!*

*Driving on ascending and descending gradients carries special dangers!*

#### **Always follow the instructions below.**

- Reduce the driving speed on descending gradients. Always limit travel speed to 4.8 km/h or less.
- On ascending and descending gradients, the load must be carried facing uphill.
- It is only permitted to drive on ascending and descending gradients that are marked as traffic routes and that can be used safely.
- It is not permitted to drive on long ascending and descending gradients greater than 14% with laden /15% with unladen due to the specified minimum braking and stability values.
- Before driving on ascending and descending gradients greater than 14% with laden /15% with unladen, consult the authorized service centre.

*On slopes and inclines always carry the load facing uphill, never approach at an angle or turn.*



## 1.6 Operator daily checklist

At the beginning of each shift, inspect your truck by using the manufacturer Operator's Daily Checklist. If necessary, refer to the Maintenance section of this manual for details on how to carry out this inspection. Check for damage and maintenance problems. Any necessary repairs must be completed before the truck is operated. In addition to daily inspection, scheduled maintenance is vital to safe operation of the truck. Adhere to the inspection, lubrication and maintenance schedule given in the Maintenance section of this manual.

Operator Daily Checklist is a sample list of operator daily checks. The key contents listed in this table are formulated according to the check and operation before starting daily work in Section E, and can also be added according to the requirements of users. It is necessary to print and record the contents related to forklift for your safety and longer use of forklift.

## Operator's Daily Checklist

Date \_\_\_\_\_ Operator \_\_\_\_\_  
 Truck No. \_\_\_\_\_ No. \_\_\_\_\_  
 Department \_\_\_\_\_  
 Runtime \_\_\_\_\_  
 Meter Reading \_\_\_\_\_

Daily Check Items	O.K.(√)	Remark
Check Travel Controls for binding or looseness.		
Check the entire truck as well as the surface beneath it for signs of fluid leakage.		
Check Chains, Cables, and Hoses that they are in place, secured correctly, functioning properly and free of binding or damage.		
Check Decal Condition		
Test service brake and parking brake, emergency stop switch can be disengaged and reengaged.		
Check the drive wheels for cracks or damage. Move truck to check load for freedom of rotation.		
Check battery charge and condition.		
Check operation of lift and lower to their maximum positions. Check side shift operation if applicable.		
Check that all hardware (nuts/bolts) are secure and free of damage.		
Check for binding or looseness in steering arm when steering.		
Check the mast, load backrest and forks for visible damage such as cracks. Ensure the fork pins are latched.		
Check that horn sounds when operated.		

---

## F Battery Maintenance & Charging

### 1.1 Battery type & dimension

Battery type & dimension as follow:

Tuck type	Battery type	voltage/ rated capacity	Dimension(mm)	Charger	Charging time(h)
CPD50L1	Lithium-ion Battery	80V/560AH	810*692*672	200A	around 3



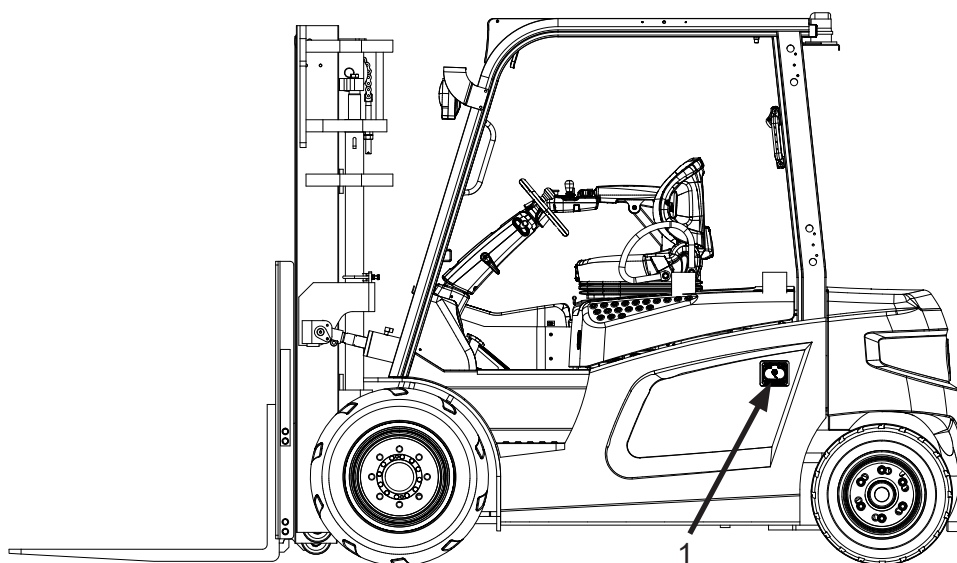
## 1.2 Charging the battery

### Safety regulations for Charging the battery

- Avoid the existence of any metal object in the surface of the battery;
- Do not pierce the battery case with nails or other sharp objects.
- Do not short-circuit the battery with wires or other metal objects!
- The plug connection parts should be inspected in terms of obvious damages before charging;
- Fire-fighting equipment must be kept in the charging place;
- Before charging, check if there is damage on cable connection and plug connection pieces.
- Do not use irregular charging sockets;
- The net height of the charging area shall be higher than 5m, and the safe distance from other areas shall be greater than 5m. Charging in non-charging area is prohibited;
- No inflammable substances or spark-generating materials being present or stored within a distance of 2 metres of the truck parked for battery charging.
- No smoking or open fire around when charging.
- When charging, do not wrongly connect the battery polarity, otherwise it may damage the battery.
- The safety provisions related to the battery and the manufacturer of charging station must be strictly abode by.

### ➤ Charging Procedure

- Insert the electric switch key and turn clockwise.
- Tilt the lift mast forwards slightly. The truck must be stationary on the ground.
- Apply the parking brake pedal.
- Press the emergency stop switch.
- Press the cover (1) and open automatically.
- Connect charger connector to the battery *plug*.
- Switch on the charger and charge the battery in accordance with the battery and charging station manufacturers' instructions.
- After the battery is fully charged. first close the charger then remove the connector.



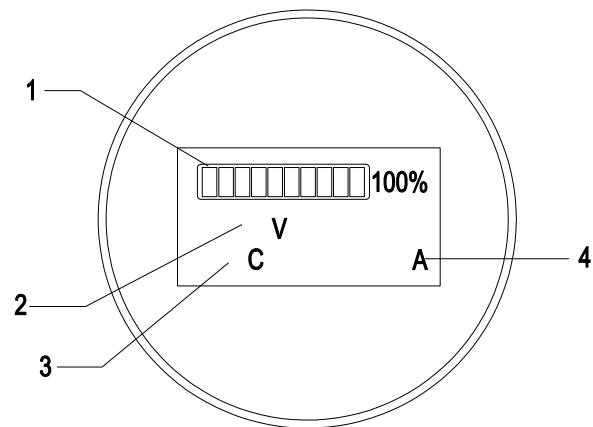
**i** NOTE

The battery charging station should be plugged into a standard 380V, 3-phase, 50/60Hz walloutlet. Maximum input power is 14.4 KW . Please strictly implement the above data to prevent equipment damage and accidental risks such as fire.



**WARNING**

The battery plug may only be withdrawn or connected when the main switch and the charging equipment are switched off.



**WARNING**

Damage to battery and charger!

The charger must be matched to the battery in terms of voltage and charging capacity!

Observe the correct combination of battery and charger to avoid overheating and fire hazard.

Only use the charger that is suitable for the corresponding battery.



**WARNING**

After parking and recharging, wait for the lithium-ion battery meter (3) temperature > 5 °C before charging.



**WARNING**

If the truck equipped with heating system can be charged at low temperature. After plugging the battery into the charger, it will be heated above 0 before charging.

Output voltage, current and application range of the charger must match the battery, otherwise it will influence the volume and service life of the battery.

Charging cable polarity must match the charger output terminal polarity.



**WARNING**

Recharge the battery in time. Do not keep the battery fully discharged or lower than 20%.

➤ **Checking the battery level**

- Apply parking brake pedal.
- Press the emergency stop switch.
- Insert the electric switch key and turn clockwise.
- Check the power level shown on the discharge indicator.

**i** NOTE

Charge and maintain the battery in accordance with instructions from the manufacturer. If there are no instructions, please contact your maintenance agent. Optional battery chargers must also be operated according to instructions.

**i** **NOTE**

*Capacity will be reduced when used in low-temperature environments.*

➤ **Storage**

If batteries are taken out of service for a lengthy period they should be stored in the fully charged condition in a dry, frost-free room.

If the battery is not used for an extended period, it must receive a supplementary charge every month to prevent permanent damage to the battery.

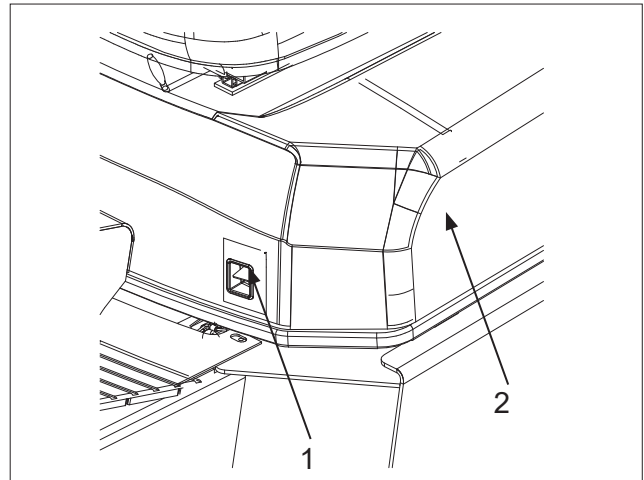
### **1.3 Battery removal and installation**

Park the truck securely(See page E2 chapter parking) ) and turn off the power before removal and installation of the battery.

- The truck must be parked on level ground. Place the battery connector or the battery cable in such a way that they will not get caught on the truck when the battery is withdrawn.
- When transporting batteries with the aid of a crane, ensure that the crane is of adequate capacity (the battery weight is indicated on the battery identification plate at the battery trough). The lifting gear must exert a vertical pull so that the battery container is not compressed. Attach the hooks to the battery hand(or battery strap) in such a way that the lifting gear, when slack, cannot collapse on the battery cells.
- When removing the battery make sure it does not get caught on the battery panel,causing the truck to tip over.
- After installing the battery, check all cables and plug connections for visible signs of damage. Ensure that the battery is firmly secured in the truck to prevent any damage caused by sudden movements of the truck. Whenever you replace the battery make sure it cannot slide. The battery cover must be securely closed and locked.

## ➤ Removal procedures:

- Open the snap close(2) first then the hood(1) can be open with the *gas air spring*.



### WARNING

*When removing the gas air spring, prevent the falling hood from clamping your fingers.*

Unplug the battery(3), disconnect the signal wire and harness.

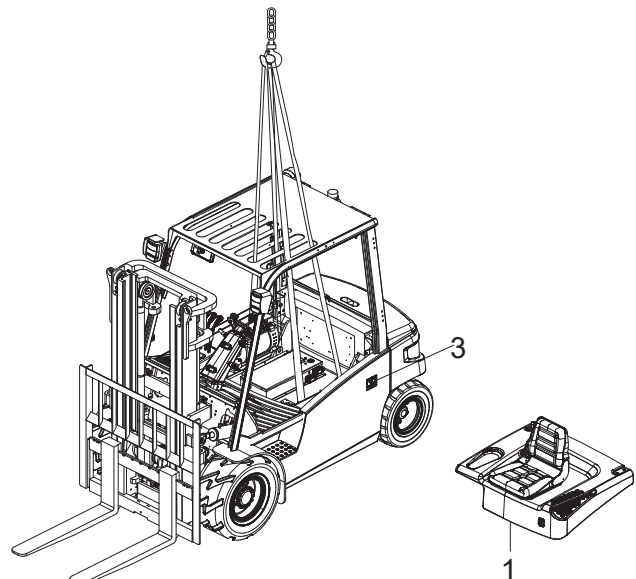
Attach the lifting hook to the battery sling hole(4), Lift the battery to a proper height through the sling tool and use another forklift to carefully fork out the battery from the side;



### WARNING

*Lift carefully. The lithium-ion battery is very heavy.  
Prevent crushing or pinching your hands during removing.*

Install according to the reverse order of removal.



### WARNING

*After installing the battery hood, When it is closed, press the red button(see chapter component- air spring) on the air spring pipe, then the lock will be released. Press the hood head, you can shut it down, and the hood is locked after you hear click sound. Prevent crushing or pinching your hands during close the hood.*



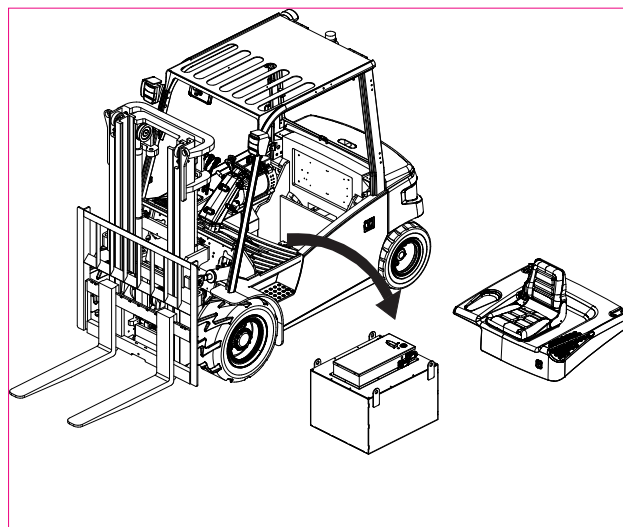
**CAUTION**

The battery must be secured so that it does not slide. Please contact your dealer if necessary.

**1.4 Battery maintenance (See**

**APPENDIX)**

Lithium Battery Use and Maintenance Manual



## G Truck Maintenance

### 1.1 Operational safety and environmental protection

- The servicing and inspection operations contained in this chapter must be performed in accordance with the intervals indicated in the service checklists.
- Only use original spare parts that have been certified by our quality assurance. Used parts, oils and fuels must be disposed of in accordance with the applicable environmental protection regulations. Upon completion of inspection and servicing, carry out the activities listed in the "Recommissioning" section.

### 1.2 Maintenance Safety Regulations

#### ➤ Servicing and maintenance personnel:

Only qualified personnel authorized by the owner are permitted to perform maintenance or repair work. All items listed in the Scheduled Maintenance Charts must be performed by qualified technicians only. They must have knowledge and experience sufficient to assess the condition of a truck and the effectiveness of the protective equipment according to established principles for testing trucks. Any evaluation of safety must be unaffected by operational and economic conditions and must be conducted solely from a safety standpoint.

Daily inspection procedures and simple maintenance checks, e.g. checking the hydraulic oil level or checking the fluid level in the battery, may be performed by operators. This does not require training as described above.

#### ➤ Lifting and jacking up:

When a truck is to be lifted, the lifting gear must only be secured to the points specially provided for this purpose.

When jacking up the truck, take appropriate measures to prevent it from slipping or tipping over (e.g. wedges, wooden blocks).

#### ➤ Cleaning operations:

No inflammable liquids must be used when cleaning the truck. Prior to commencing cleaning operations, all safety measures that are required to prevent sparking (e.g. by short circuits) have to be taken. For battery-powered trucks, the battery plug must be removed. Only weak pressure, weak compressed air and non-conducting, antistatic brushes must be used for the cleaning of electric or electronic assemblies.

#### ➤ Work on the electric system:

Work on the electric system of the truck must only be performed by personnel specially trained for such operations. Before commencing any work on the electric system, all measures required to prevent electric shocks have to be taken. Take off the metal accessories from the hand before checking the forklift electrical system.

➤ **Settings**

When repairing or replacing hydraulic, electric or electronic components or assemblies, always note the truck specific settings.

➤ **Hydraulic hoses**

The hoses must be replaced every six years. When replacing hydraulic components, also replace the hoses in the hydraulic system.

➤ **Maintenance operations that do not require special training**

Simple maintenance operations such as checking the hydraulic fluid level or checking the battery electrolyte level (if necessary) can be carried out by persons with no special training. A specific qualification is not necessary.

Complicated maintenance operations such as replacing the battery, replacing the wheels and so on should be carried out by the authorised service centre.

Refer to the maintenance section of this manual for further information.

### 1.3 Servicing and inspection

Thorough and expert servicing is one of the most important requirements for the safe operation of the industrial truck. Failure to perform regular servicing can lead to truck failure and poses a potential hazard to personnel and equipment.

The service intervals stated are based on single shift operation under normal operating conditions. They must be reduced accordingly if the truck is to be used in conditions of extreme dust, temperature fluctuations or multiple shifts.

The following maintenance checklist states the tasks and intervals after which they should be carried out. Maintenance intervals are defined as:

W = Every 50 service hours, At least once per weeks

A = Every 250 operating hours, At least once a month and a half

B = Every 500 operating hours, At least once per quarter

C = Every 1000 operating hours, At least once half year

D = Every 2000 operating hours, At least once per year

In the run-in period - after approx. 100 service hours - or after repair work, the owner must check the wheel nuts/bolts and re-tighten if necessary.

### 1.3.1 Maintenance Checklist

		Maintenance interval●				
		W	A	B	C	D
<b>Before starting maintenance work:</b>	Parking the truck securely and cut off the power supply. Using wooden blocks to prevent wheel from moving.					
	Clean the fork lift truck if necessary					
	Check the time and date settings on the display unit; adjust if necessary.					
	Check for error codes on diagnostic software and delete.					
<b>Functions and Control</b>	Check the functions of the operation switches and display	●				
	Check alarm system functions	●				
	Check parking brake functions	●				
	Check the emergency switch functions	●				
	Check the steering wheel functions	●				
	Check the cables for damage and if the terminals are secure		●			
	Check the seat switch functions					
	Check accelerator pedal functions	●				
	Check and tighten the controllers and contactors					●
	Check fault information records and operating hours				●	
<b>Power Supply &amp; Drive System</b>	Check the battery cables for damage and replace if necessary				●	
	Check the battery charge connector				●	
	Check if the cable connections between battery monomers are secure, apply some grease to electrodes if necessary				●	
	Check electrolyte fluid level (featuring lead-acid battery)				●	
	Check electrolyte density(featuring lead-acid battery)				●	
	Check battery temperature				●	
	Check battery locking mechanism(if necessary)				●	
	Check and tighten motor mounting bolts					●
	Check the connections of motor connectors					●
	Check the position of various bearings for noise			●		
	Check heavy duty gear oil level			●		
	Check the gearbox for abnormal noise or leaks			●		
	Check the drive wheel and steering wheel for wear or damage			●		
	Check and lubricate the wheel bearings			●		
Check the travel speed			●			



		Maintenance interval●				
		W	A	B	C	D
<b>Chassis System</b>	Mast and tilt cylinders, Check fastening.			●		
	Check the counterweight, motors, chassis, speed reduction gearbox, overhead guard and steering axle fastenings.			●		
	Check and lubricate the other pins and swivel points.			●		
	Check the chassis for cracks or damages					●
	Check front and rear wheel fastenings and tighten. (after each maintenance or repair, at the latest after 100 hours).		●			
	Check/lubricate the steering axle.			●		
<b>Operating devices</b>	Checking the joystick pad			●		
	Checking and lubricating the pedal mechanisms			●		
	Check the horn for correct function.			●		
<b>Mast System</b>	Check the mast for damages					●
	Clean and lubricate the rolling surface of lift mast column with grease		●			
	Check and lubricate mast rollers			●		
	Check the fixation of lift mast				●	
	Check the tubing on mast for connections and leaks			●		
	Check the side shifter functions(if necessary)	●				
	Check and lubricate the chains			●		
	Check and adjust the lifting chains.				●	
	Check the fork carriages for wear and damage				●	
	Visual inspection of rollers, sliders and stoppers				●	
	Check the lifting and lowering speed					●
<b>Hydraulic System</b>	Check the functions of hydraulic system	●				
	Check if the hoses, pipes and interfaces are fastened or sealed securely, and check if there is damage				●	
	Check the connections of pump motor connectors					●
	Check and tighten pump motor mounting bolts					●
	Check gear pump has abnormal sound				●	
	Check the gear pump fixation and check for leaks				●	
	Check the cylinders for leaks				●	
	Check the cylinders for damages and check the fixation					●
	Check the oil tank fixation and check for leaks					●
	Check the hydraulic oil level				●	
	Clean or replace the hydraulic oil					●
	Check and clean oil tank air filter				●	
	Replace the oil tank air filter and filter					●
	Check the relief pressure					●
					●	

		Maintenance interval●				
		W	A	B	C	D
<b>Braking System</b>	Test the release of brake pedal is normal	●				
	Check the brake fluid level			●		
	Test the release of emergency stop switch is normal	●				
	Test parking brakes is normal	●				
	Check the brake pump and piping connections for leaks			●		
	Check the release of brake pedal is normal			●		
	Check the braking distance of brake				●	
<b>Other</b>	Check if the signs are clear and complete				●	
	Carry out a functional test and test drive.				●	
	Check the seat belt and functions	●				
	Checking covering parts for damages					●
	Check if the optional features are functioning properly	●				

**i** NOTE

*If the forklift truck is used in an extreme environment (such as excessive heat, excessive cold or areas with high dust concentrations), the time intervals given in the maintenance tables should be reduced accordingly.*

➤ **Periodic replacement of safety-critical parts**

- Some parts are difficult to inspect during periodic maintenance. Therefore, in order to further improve safety, users should carry out periodic replacement of the parts listed in the following table.
- If any of these parts are found to be damaged or faulty before they are due for replacement, they should be replaced immediately.

Name of safety-critical part	Useful life (years)
Brake hose or rigid pipe	1~2
Lifting system hydraulic hoses	1~2
Lifting chain	2~4
Hydraulic system high-pressure hoses	6
Brake fluid cup	2~4
Hydraulic system inner seals and rubber parts	2
Cushion for steering axle	4

### 1.3.2 Lubrication Points

#### ➤ Lubricant

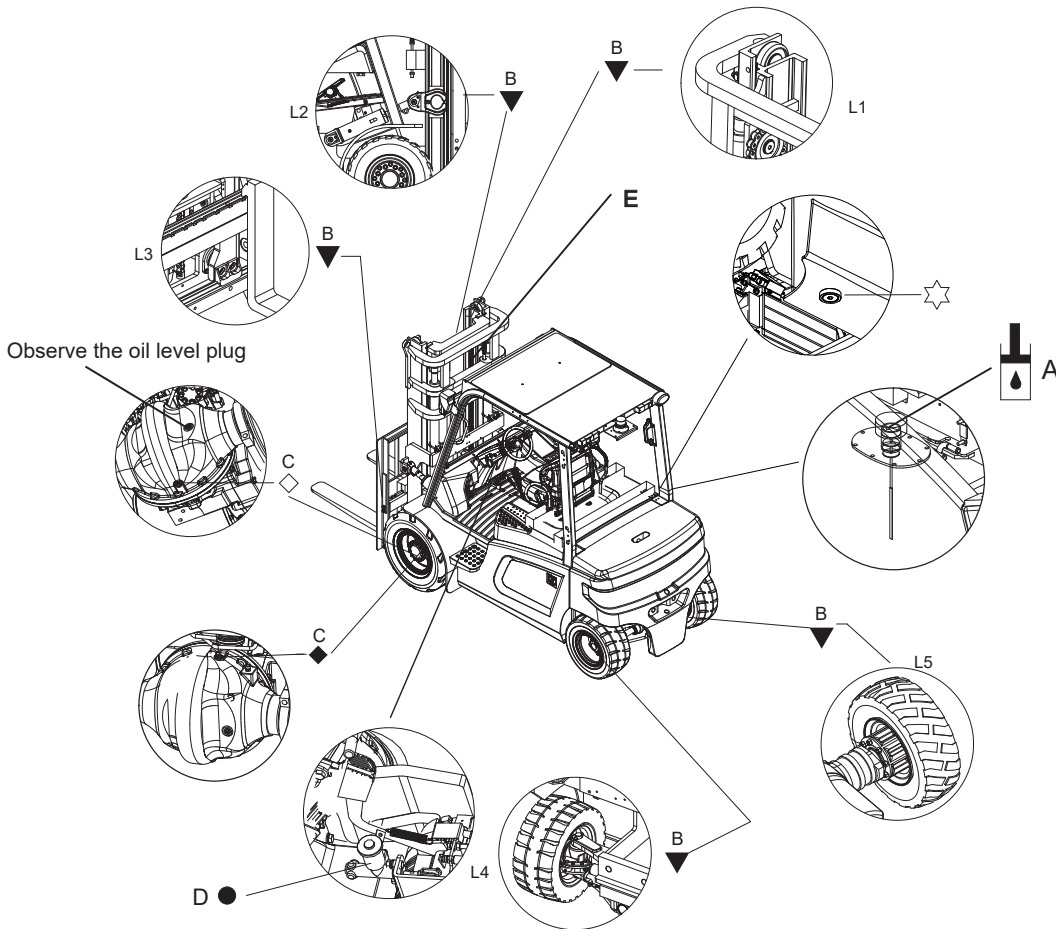
Improper operations may pose hazards to the operator's health and life, as well as to the surrounding environment.

When storing or adding lubricant, use clean containers. It is strictly forbidden to mix different types and specifications of lubricants (except for those can be mixed under clear statement).



#### CAUTION

*The use and disposal of lubricants must be carried out in strict accordance with the manufacturer's regulations.*



▼ Contact surface



Hydraulic oil injection nozzle

◆ Gear oil injection nozzle

◇ Gear oil discharge nozzle

● Brake fluid

☆ Hydraulic oil discharge nozzle

Table 1 Lubricants				
Code	Type	Specification	Amount	Position
A	Hydraulic oil	L-HM46 (Cleanliness grade 9, in compliance with NAS1638)	See Table1	Hydraulic System
B	Multi-purpose grease	Polylub GA352P	Appropriate amount	Contact Surface (See Table2)
C	Heavy duty gear oil	85W-90GL-5	about 8L (add until oil level Observed oil level plug overflows)	Drive axle
D	Brake Fluid	ZSM207DOT3	After the gas within the system is completely discharged, add to 2/3 of the oil cup	Brakes
E	Spray chain	/	Appropriate amount	Mast chain



### WARNING

*Be careful*

*when adding and avoid dropping when lubricating on high position. Chain lubrication, Coat the lift guide wheel and the contact surfaces on the inner and outer sides of the mast with a layer of grease.ect*

Table 2 Contact Surface Lubrication Table	
Code	Position
L1	Steel channel, Rollers
L2	Tilt cylinder connetor
L3	Fork Carriage
L4	Steering axle
L5	Driving axle (if necessary)

<b>Table 2.1 Application Amount of Hydraulic Oil - 1</b>		
<b>Mast Series</b>	<b>Lifting height (mm)</b>	<b>Amount (L)</b>
2-stage Mast	3000	45
	3300	46
	3500	46
	3700	46
	3750	46
	4000	47
	4250	47
	4500	48
	4750	48
	5000	49
	5500	50
6000	51	

<b>Table 2.1 Application Amount of Hydraulic Oil - 2</b>		
<b>Mast Series</b>	<b>Lifting height (mm)</b>	<b>Amount</b>
2-stage Full Mast	2300	44
	2430	44
	2610	45
	2710	45
	3000	46
	3300	46
	3500	47
	3750	47
	4000	48
	4500	49
	5000	50
	5500	51
	6000	52
	3-stage Full Mast	3920
4350		49
4500		49
4700		50
4800		50
5000		51
5400		52
6000	53	

## 1.4 Maintenance Instructions

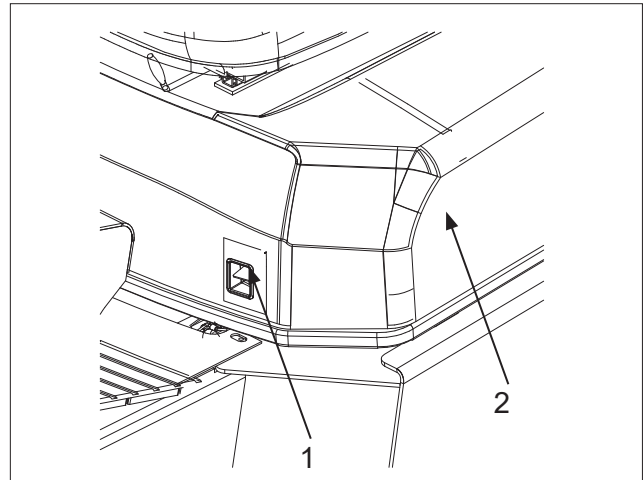
### ➤ Prepare the truck for maintenance and repairs

All necessary safety measures must be taken to avoid accidents when carrying out maintenance and repairs. The following preparations must be made:

- Park the truck securely ( See page E2 chapter parking).
- Remove the key to prevent the truck from improper operation.
- When working under a raised lift truck, secure it to prevent it from tipping or sliding away.

### ➤ Open the battery hood

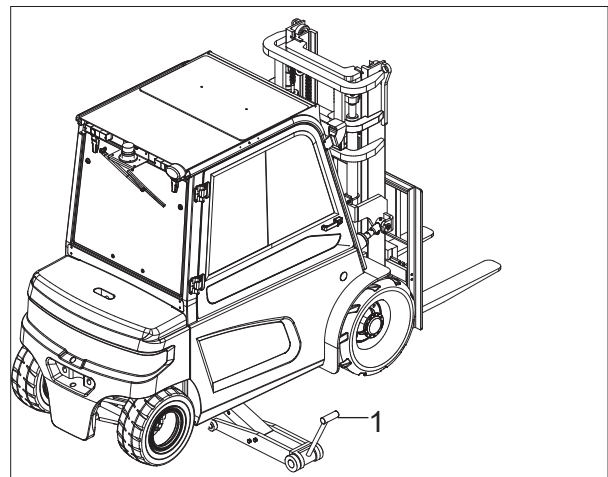
Press the switch(1), open the battery hood(2), remove the air spring and battery hood;



### 1.4.1 Steer Wheels Removal and Installation

#### ➤ Removal

- Jack up the vehicle with lifting equipment(1), make the steer wheels off the ground;
- Power off and place a wooden wedge under the chassis near steer wheel, make the wheel off the ground;
- Remove the eight lock nuts (1) on the steer axle assembly (3).
- Remove the steer wheels(2).



#### ➤ Installation and Commissioning

Install according to the reverse order of removal. Install according to the reverse order of removal. Install the new tire on the hub, and screw down the hub nut symmetrically and crosswise.

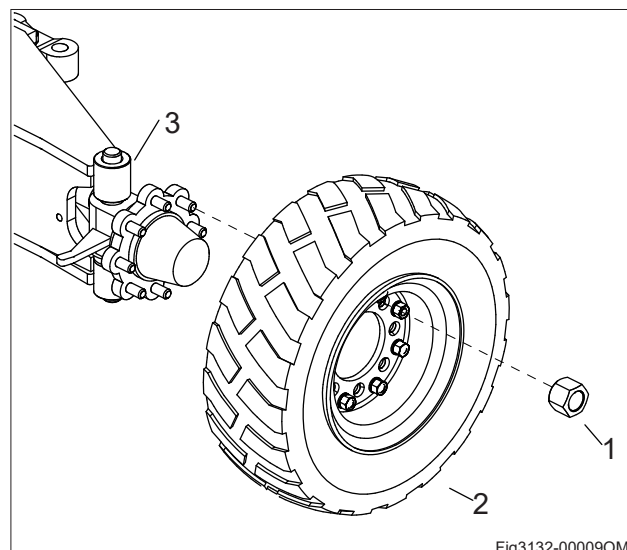


Fig3132-00009OM

### 1.4.2 Drive Wheels Removal and Installation

- Jack up the vehicle with lifting equipment (1), make the drive wheels off the ground;
- Power off and place a wooden wedge under the chassis near drive wheel, make the wheel off the ground;
- Remove the six lock nuts (2) on the Drive axle assembly(4) .
- Remove the drive Wheels (3).

#### ➤ Installation and Commissioning

Install according to the reverse order of removal. Install according to the reverse order of removal. Install the new tire on the hub, and screw down the hub nut symmetrically and crosswise.



#### **WARNING**

*Tire is solid tire. When replacing wheels, be sure that the truck won't tilt.*



#### **WARNING**

Make sure that wooden blocks used to support forklift truck are solid, one-piece units.  
Never get under the forklift when the forklift is only supported with wood block.



#### **WARNING**

*Do not take out wheel nuts before the rear leave the ground.*



#### **NOTE**

*The wheels must only be replaced by authorized service personnel.*

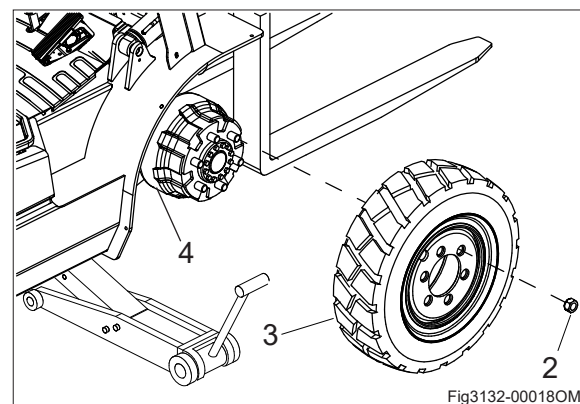
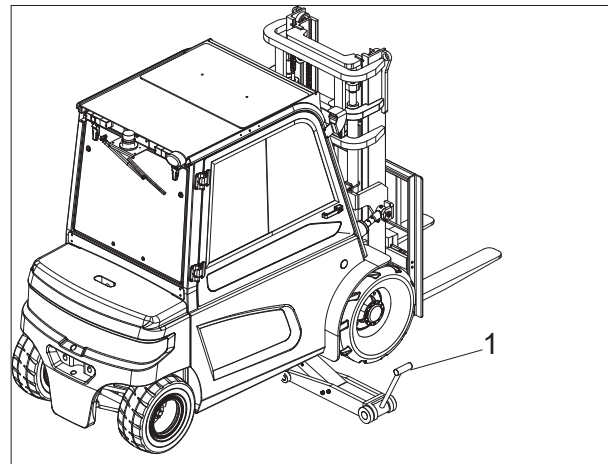


Fig3132-00018OM

#### Steer Wheels

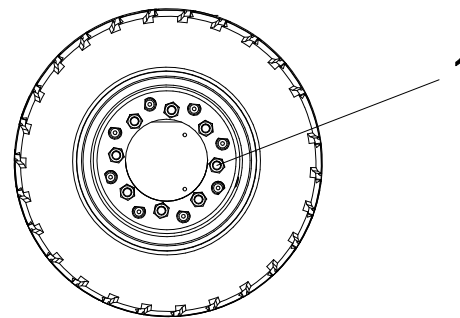


Fig3845-00009OM

#### Drive Wheels

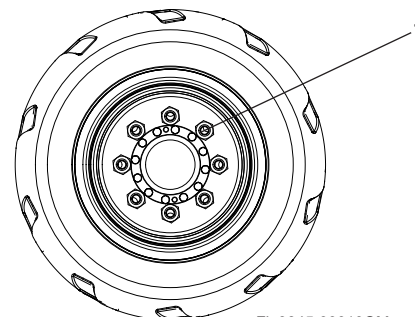


Fig3845-00010OM



### CAUTION

- Screw the six nuts.
- Tighten the nuts of steer wheels in order and mark with the torque: 206-243Nm.
- Tighten the nuts of driving wheels in order and mark with the torque: 440-480Nm.
- Turn the wheel to see if it is rotating smoothly, and if there is blocking or not.
- Run the truck to see if the wheels are functioning properly. If there is blocking or noise, please check if the wheel bearings are functioning properly.



### CAUTION

Quality of tyres directly affects the stability and driving performance of the device. If you need to replace the factory-fitted tyres, please use original spare parts provided by the equipment manufacturer to reach the original design performance of the truck.



### CAUTION

The nuts must be tightened at least once every 250 operating hours.

#### 1.4.3 Checking whether the Drive Axle is leaking

Check the lubrication ports on the bottom of Drive Axle. If there is leakage, please contact your dealer.

#### 1.4.4 Checking the status and tightness of the electrical cables, electrical connections and plug connectors



### NOTE

Press the emergency stop button before carrying out this maintenance task.

- Open the battery cover(see chapter G Section1.4).
- Motor terminals: check the tightness of the connections and whether there is any oxidation or rust.
- Check that the battery cables are secure.
- Check the cables whether there is damage to the insulation and the tightness of the connections.



### NOTE

Oxidised and rusted connections and broken cables will lead to a drop in voltage, causing the truck to malfunction.

Remove the oxidised rust then lubricate, or replace the broken cables.



## 1.4.5 Check the hydraulic oil level

- Prepare the truck for maintenance and repairs
- Open the battery hood(see chapter G Section1.4).
- Remove the oil cover (1).
- Fill the hydraulic oil up to the proper amount(See Table 1 Application Amount of Hydraulic Oil - 1).
- Reinstall the oil cover.



### WARNING

Please follow the procedures for the safe handling of oil and lubricating grease.



### NOTE

The oil level can only be checked after lowering the lift mast.

### Replace hydraulic oil

Hydraulic oil should be changed every 2000h;

- Park the truck on level ground;
- Turn the steering wheel right to the end, make the oil drain plug have enough space;
- Tilt the mast backward to the end and drop the forks on the ground;
- Apply the parking brake;
- Open the cover, screw off the oil filler cap (1) of the fuel tank, and take out the dipstick;
- Put one container under the truck frame, remove oil plug (2), and drain oil;
- Take away the container, dispose waste oil according to local environmental law, and do not dump at will;
- Screw back the drain plug(2), add new hydraulic oil and check for leakage;
- Start forklift, raise forks for 3-5 times, and tilt the mast forward or backward for 3-5 times;
- Add oil to specified scale.

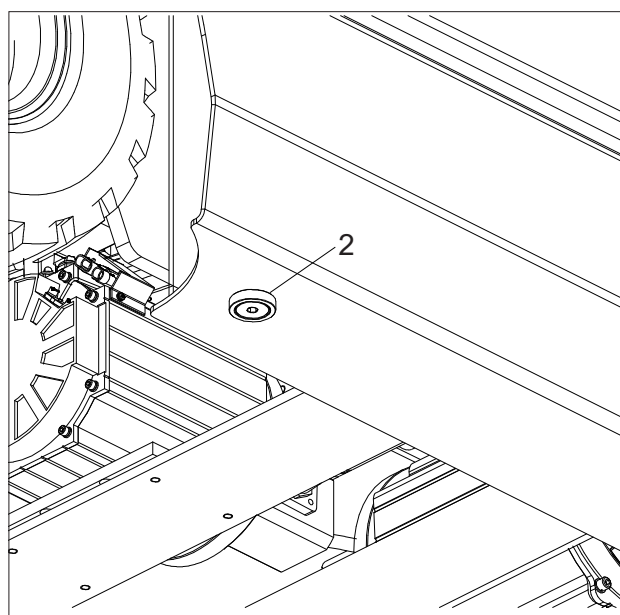
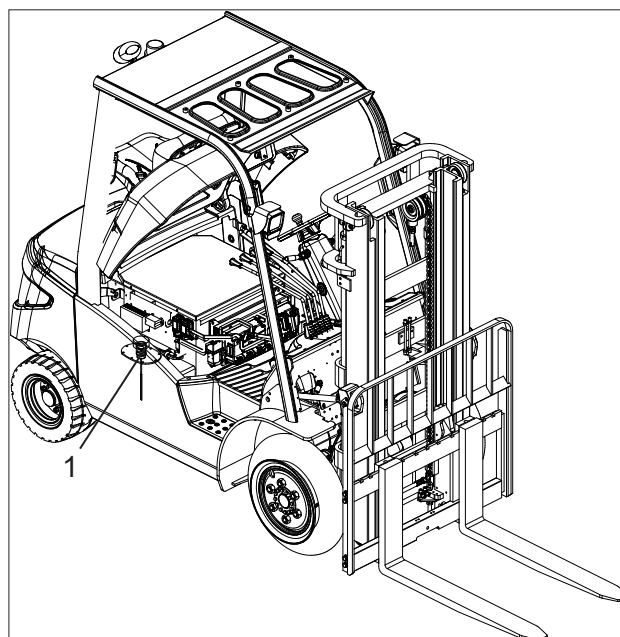


Fig3132-00028OM

### 1.4.6 Check the electrical fuses

- Prepare the truck for maintenance and repairs.
- Open the battery hood.
- A melting fusible link can be watched or touched easily, if it is uncertain of melting, use multi meter or lamp to test.

#### **i** NOTE

Check rating of the fuses in accordance with your parts manual or service manual.

#### **WARNING**

When replacing for new fuses, please choose the fuse of same capacity as the old one.

1. If fusible links is melted, maybe because of short circuit(power or current is too high). No matter which reason, please check and eliminate fault.
2. Fusible links can cause heat, do not enlace with adhesive tape. Do not put fusible links near other rubber or wiring assembly.

### 1.4.7 Fork Inspection

Inspect the load forks for bending and wear:

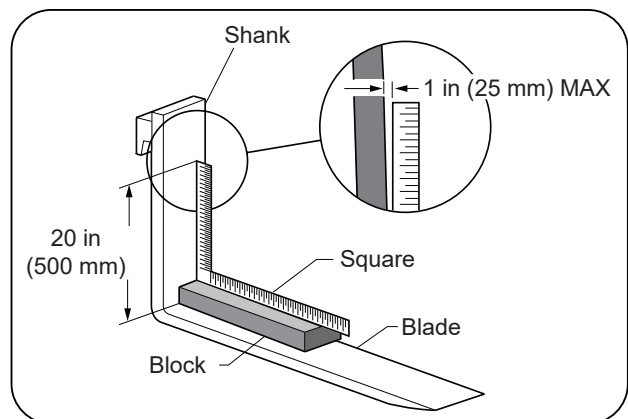
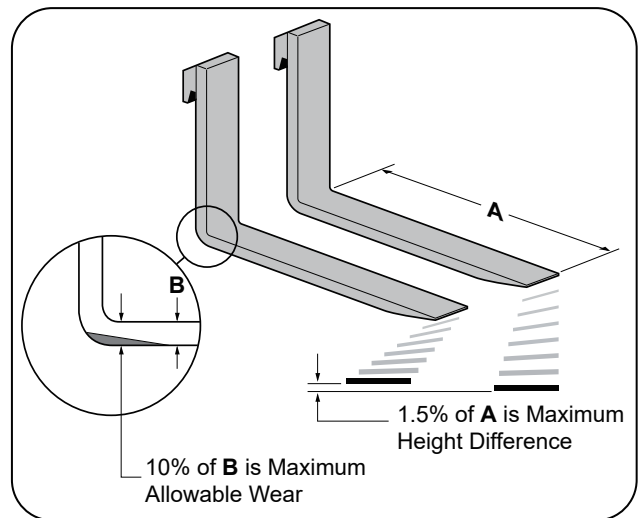
- The top surfaces of the forks should be level with each other.
- If the height difference between the fork tips is greater than 1.5% of the blade length (A), then the forks must be replaced.
- If the fork heel is worn by more than 10% of the thickness (B) of the fork blade, then the forks must be replaced. The load capacity of the forks is reduced when the forks have experienced excessive wear.

#### Inspect the forks for twists and bends:

- Position a 50 mm thick block, at least 100 mm wide and 600 mm long, on the blade of the fork with the 100 mm square against the blade.
- Position a 600 mm square on the top of the block and against the shank.
- Check the fork gap at 500 mm above the blade. If the gap distance is greater than 25mm, then the forks must be replaced.

#### **WARNING**

Do not operate a lift truck with bent, damaged, or worn forks.



### 1.4.8 Lift Chain Inspection and Lubrication

During normal operating conditions, inspect and lubricate the lift chains every 450 to 500 hours. If operating in corrosive or extreme working conditions, inspect more frequently.

When inspecting, check for: rust and corrosion, cracked plates, raised or turned pins, tight joints, excessive wear, and worn pins and holes.

Lift chain lubrication is a crucial step of your Planned Maintenance program. The correct and

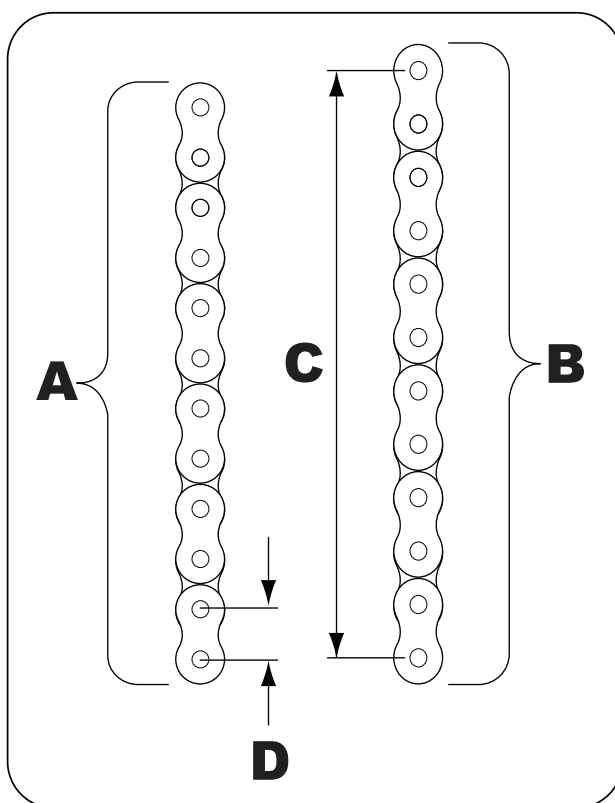
timely lubrication of the lift chains will maximize their service life.

Lift Chain Wear and Replacement Criteria:

The lift chain will gradually stretch over time during normal operation. When a section of chain has stretched 3% or more, it is considered excessively worn and must be replaced.

When checking for chain stretch, always measure a segment of chain that moves over a sheave.

- New Chain Length (A): distance from the first pin counted to the last pin counted in a span while the chains are lifting a small load.
- Worn Chain Length (B): distance from the first pin counted to the last pin counted in a span while the chains are lifting a small load.
- Span (C): number of pins in the segment of chain to be measured.
- Pitch (D): distance from the center of one pin to the center of the next pin.



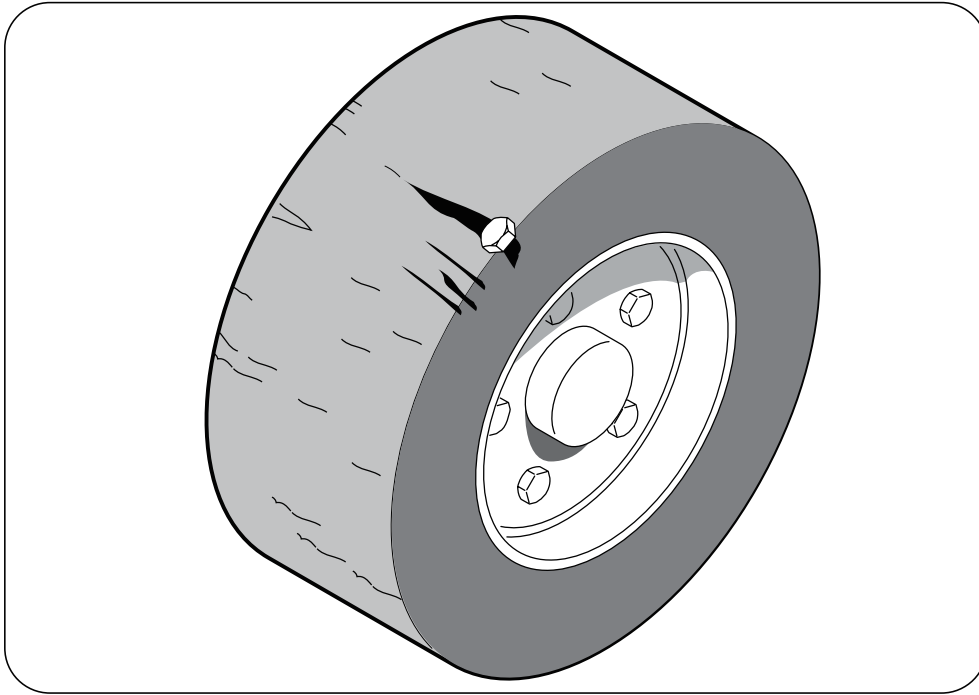
#### **WARNING**

*Do not attempt to repair a worn or broken lift chain.*

#### **1.4.9 Inspect the drive and steer wheels and tires every day before operating the lift truck**

Do the following when inspecting the wheels and tires:

- Inspect the tires for excessive wear. Replace if needed.
- Remove any embedded foreign objects for the tires.
- Inspect the tire for large cracks or missing chunks.
- Check for missing wheel lugs.
- Check for loose fasteners. Tighten any loose or replaced fasteners to the correct specification. Refer to your lift truck's Service Manual for the correct specifications.



## 1.5 Cleaning

### Cleaning the truck



#### WARNING

- Risk of fire due to flammable cleaning materials!
- Flammable cleaning materials can be ignited by hot components.
- Do not use any flammable cleaning materials.



#### CAUTION

- If water penetrates the electrical system, there is a risk of short circuit!
- Excessive water pressure or water and steam that are too hot can damage truck components.
- Abrasive cleaning materials can damage the surfaces of components!
- Using abrasive cleaning materials that are unsuitable for plastics can cause plastic parts to dissolve or become brittle. The screen on the display-operating unit could become cloudy.
- Adhere strictly to the following steps:
- Park the truck safely.
- Switch off the key switch.
- Do not spray electric motors and other electrical components or their covers directly with water.
- Use only high-pressure cleaners with a maximum output power of up to 50 bar and 85°C.
- If a high-pressure cleaner is used, maintain a distance of at least 20 cm between the nozzle and the object being cleaned.
- Do not aim the cleaning jet directly at adhesive labels or decal information.
- Remove all deposits and accumulations of foreign materials in the vicinity of hot components.
- Use only non-flammable fluids for cleaning.
- Clean plastics only with cleaning materials intended for plastics.
- Clean the truck exterior using water-soluble cleaning materials and water. Cleaning with a sponge or a cloth is recommended.
- Clean all accessible areas.
- Before lubrication, clean the oil filling openings and the area around the oil filling openings, as well as the lubricating nipples.

#### ➤ Cleaning the electrical system

- Danger of electric shocks due to residual capacity!
- Never reach into the electrical system with your bare hands.
- Cleaning electrical system parts with water can damage the electrical system.
- Cleaning electrical system parts with water is forbidden!

Clean the electrical system parts with a metal-free brush and blow the dust off with low-pressure compressed air.

## ➤ Cleaning load chains



### **WARNING**

*The use of cold/chemical cleaners or fluids that are corrosive or contain acid or chlorine can damage the chains and is forbidden!*

- Place a collection vessel under the lift mast.
- Clean with paraffin derivatives, such as benzine.
- When using a steam jet, do not use additional cleaning agents.
- Remove any water in the chain links using compressed air immediately after cleaning.
- Move the chain several times during this procedure.
- Immediately after drying the chain, spray it with chain spray. Move the chain several times during this procedure.

## 1.6 Decommissioning the trucks

The truck must be parked in a frost-free, clean, dry location and 0-40°C condition. Parking the forklift in an environment below 0 ° C for a long time is forbidden.

### **Daily storage**

- Park the forklift in a designated area and chock the wheels.
- Put the shift lever in neutral.
- Engage the hand brake.
- Turn off the key switch. Operate the multi-way valve lever several times to release the residual pressure in the cylinders and lines.
- Disconnect the power plug.
- Remove the key and keep it in secure place.
- Press red emergency stop button.

### **Long-term storage**

Do the following maintenance and check on the basis of daily storage

- Disconnect the battery plug to prevent discharge and store the vehicle in a dark place.
- Apply anti-corrosion agent to shafts, rods and other exposed parts.
- Cover the breather and other openings where moisture may enter.
- Fully cover the vehicle with a sheet or similar.
- Lubricate with oil or grease where necessary.
- Support the underside of the body and counterweight with wooden blocks to reduce the weight on the rear wheel.



### **WARNING**

*The wooden blocks must be single pieces that are sturdy enough to support the weight of the forklift.*

*Do not use wooden blocks that are more than 300mm (11.81 inches) in height.*

*Raise the forklift just enough to allow it to be placed onto the wooden support blocks.*

*Place wooden blocks of identical size under left and right sides of the frame.*

*After supporting the forklift with the wooden blocks, move the forklift back and forth from all four sides to make sure that it is safely secured.*



### **WARNING**

*After parking and recharging, wait for the meter temperature > 5°C before charging.*

### 1.6.1 Prior to decommissioning

- Clean the truck thoroughly.
- Lift and lower the fork carriage to its full extent and tilt the lift mast forwards and backwards several times. Repeat the same operation several times on attachments if they exist.
- Check the brakes
- Check the hydraulic oil level and top up if required.
- Apply a thin layer of lubricating oil or grease to all nonpainted mechanical components.
- Lubricate the trucks in accordance with the lubrication schedule.
- Remove the battery and recharge it at least once two month.
- Clean the battery and apply specialised grease to the terminals.
- Spay all exposed electrical contacts with a suitable contact spray.



#### **WARNING**

*Charge the battery every two months to avoid depletion of the battery through self-discharger.*



#### **CAUTION**

*Jack up the forklift truck to prevent permanent tyre deformation.*



#### **NOTE**

*Do not cover the forklift truck with plastic film as it may gather water vapour.*

### 1.6.2 Restoring the truck to operation after decommissioning

- Thoroughly clean the truck.
- Clean the battery. Grease the pole screws using pole grease and reconnect the battery.
- Recharge the battery.
- Check if the hydraulic oil contains condensed water and change if necessary.
- Follow the daily checklist.



#### **NOTE**

*If you want to carry out maintenance on the forklift truck yourself, we recommend that maintenance be carried out by technicians appointed by the dealer at least for the first three times. Your maintenance personnel should also be present, in order to receive appropriate training.*

### 1.7 Final decommissioning, disposal

Final, proper decommissioning or disposal of the truck must be performed in accordance with the regulations of the country of application. In particular, regulations governing the disposal of batteries, fuels, hydraulic oil, plastic and electronic and electrical systems must be observed.

### 1.8 Bolt tightening torque table

Unit:N·m

Bolt diameter	Grade(Galvanized screws tightening torque Nm)				Grade(Black, untreated screws Tightening torque Nm)			
	5.6	8.8	10.9	12.9	5.6	8.8	10.9	12.9
<b>M6</b>	4.5	9.5	13	16	4.5	10	14	17
<b>M8</b>	11	23	32	39	12	25	35	41
<b>M10</b>	22	46	64	77	23	49	69	83
<b>M12</b>	38	80	110	135	40	86	120	145
<b>M14</b>	60	125	180	215	65	135	190	230
<b>M16</b>	92	195	275	330	96	210	295	355
<b>M20</b>	180	385	540	650	190	410	580	690
<b>M24</b>	305	660	930	1100	330	710	1000	1200
<b>M30</b>	620	1350	1850	2250	660	1450	2000	2400
<b>M36</b>	1050	2300	3200	3850	1150	2450	3450	4150
<b>M42</b>	1700	3650	5150	6200	1850	3950	5550	6650
<b>M47</b>	2600	5550	7800	9350	2800	5950	8400	10100



## H Troubleshooting

This chapter is designed to help the user identify and rectify basic faults or the results of incorrect operation. When locating a fault, proceed in the order shown in the table.

If the fault cannot be rectified or a fault in the electronics system is displayed with a corresponding error code after carrying out the remedial procedure, notify the manufacturer's service department, as any further troubleshooting can only be performed by specially trained and qualified service personnel. The manufacturer has a customer service department specially trained for these tasks.

Fault	Fault Symptom	Troubleshooting Order *	Troubleshooting Measures
Power supply failure	1. Whole vehicle power outage	<ul style="list-style-type: none"> <li>a. Power supply failure</li> <li>b. Fuse failure</li> <li>c. Emergency stop switch or circuit failure</li> <li>d. Key switch or circuit failure</li> </ul>	<ul style="list-style-type: none"> <li>1. Check the voltage of storage battery</li> <li>2. Check the fuses</li> <li>3. Check key switch and its circuit</li> <li>4. Check emergency stop switch and its circuit</li> </ul>
Travel Fault	1. Forward and reverse moving failures of the vehicle, but other functions are normal	<ul style="list-style-type: none"> <li>a. Parking brake switch and seat switch or its circuit connection failure</li> <li>b. Gearbox failure</li> <li>c. Travel switch or its circuit connection failure</li> <li>d. Drive motor or its circuit connection failure</li> <li>e. Controller failure</li> </ul>	<p>Controller failure error, carry out troubleshooting according to the fault code information on the instrument.</p> <ul style="list-style-type: none"> <li>1) Check if parking brake switch and seat switch or the connection of its circuit is normal;</li> <li>2) Check the gearbox;</li> <li>3) Check the travel switch and its connection circuit;</li> <li>4) Check the drive motor and its connection circuit;</li> <li>5) Replace the controller.</li> </ul>
	2. The vehicle can travel at low speed, but cannot travel at high speed	<p>Failures due to external factors:</p> <ul style="list-style-type: none"> <li>a. Motor bearing blocked</li> <li>b. Gearbox bearing blocked</li> </ul> <p>Failures due to internal factors:</p> <ul style="list-style-type: none"> <li>a. Drive motor speed encoder failure</li> <li>b. Controller failure</li> </ul>	<p>Controller failure error, carry out troubleshooting according to the fault code information on the instrument .</p> <ul style="list-style-type: none"> <li>1) Check if the motor rotation is normal;</li> <li>2) Check the speed encoder and its connection circuit;</li> <li>4) Remove the gearbox, check if the gear rotation is smooth and if there is blocking;</li> <li>5) Replace the controller</li> </ul>

Fault	Fault Symptom	Troubleshooting Order *	Troubleshooting Measures
Hydraulic Failure	1. The vehicle cannot lift	1. Pump motor does not work: <ol style="list-style-type: none"> <li>Parking brake switch and seat switch or its circuit connection failure.</li> <li>Pump motor or its circuit connection failure.</li> <li>Control switch or its circuit connection failure.</li> <li>Controller failure.</li> </ol> 2. Pump motor works: <ol style="list-style-type: none"> <li>Overload.</li> <li>Insufficient hydraulic oil.</li> <li>Hydraulic pipeline leakage.</li> <li>Pump motor reverse rotation.</li> <li>Cylinder failure (blocked).</li> <li>Solenoid valve blocked and cannot reset.</li> <li>Valve body failure: excessive wear of gear pump, serious internal leaks, insufficient pressure of relief valve or blocked, check valve blocked</li> </ol>	1. Pump motor does not work: <ol style="list-style-type: none"> <li>Check if parking brake switch and seat switch or the connection of its circuit is normal;</li> <li>Check the pump motor and its connection circuit;</li> <li>Check the control button and its connection circuit;</li> <li>Replace the controller.</li> </ol> 2. Pump motor works: <ol style="list-style-type: none"> <li>Refer to the rated capacity marked on the nameplate;</li> <li>Lower the mast to the bottom, check if the amount of oil in the oil tank can meet the requirements;</li> <li>Check the pipe and hydraulic components for oil leaks;</li> <li>Check the pump motor wiring;</li> <li>Check the cylinder for damage or deformation, remove the cylinder to check for wear or aged seals inside;</li> <li>Wash or replace the solenoid spool.</li> <li>Wash or replace the valve body</li> </ol>
	2. The vehicle cannot be lowered	<ol style="list-style-type: none"> <li>Solenoid valve (or manual valve) or its circuit connection failure</li> <li>Lowering switch or its circuit connection failure</li> <li>Valve failure;</li> <li>Cylinder deformation or blocked</li> <li>Explosion-proof valve blocked</li> </ol>	<ol style="list-style-type: none"> <li>Check the lowering button and its connection circuit;</li> <li>Check the solenoid valve and its connection circuit;</li> <li>Check the cylinder for deformation, remove the cylinder to check if the internal assembly is normal</li> <li>Clean or replace the valve;</li> <li>Replace the explosion-proof valve.</li> </ol>

Fault	Fault Symptom	Troubleshooting Order *	Troubleshooting Measures
Lift Failure	3. Slow Lifting of Vehicle	a. Overload b. Hydraulic pipeline leakage c. Valve failure: Gear pump wear, internal leakage occurs Insufficient relief valve pressure or blocked	1) Refer to the rated capacity marked on the nameplate; 2) Check the pipe and hydraulic components for oil leaks; 3) Wash or replace the valve body
	4. Slow Lowering of Vehicle	a. Solenoid valve blocking b. Valve body failure: throttle valve failure or blocked	1) Wash or replace the solenoid spool 2) Wash or replace the valve body
	5. Unstable Lifting / Lowering of Vehicle	a. Chain loosening; b. Poor lubrication between steel channel and rollers; c. Improper adjustment of rollers, or blocked.	1) Adjust the chain tension; 2) Check if the steel channel grease is normal, clean and re-lubricate steel channel and rollers; 3) Adjust the side roller spacing through roller screw; or replace the roller.
<p>* Under the circumstances of normal lifting and lowering, if failure occurs to any of other hydraulic actions (forward/backward shifting, forward/backward tilting and left/right shifting), perform troubleshooting to the corresponding control switch and its control circuit.</p>			
Steering Fault	1. The vehicle cannot be steered (the vehicle can travel)	a. Steering bridge or the tubings connection failure b. Pump motor failure c. Gear pump failure d . Pump controller failure	Controller failure error, carry out troubleshooting according to the fault code information on the instrument; 1) Check the redirector or the tubings connection; 2) Check the steering bridge or the tubings connection. 3) Check the pump motor or its connection circuit; 4) Check the pump; 5) Replace the controller.

Fault	Fault Symptom	Troubleshooting Order *	Troubleshooting Measures
Other Failures	1. Lights do not light	a. Light failure or circuit not conducted b. Lighting combination switch or its circuit connection failure c. Fuse failure	1) Check the light and its circuit connection; 2) Check Lighting combination switch and its connection circuit; 3) Check fuse and its connection circuit;
	2. Horn does not sound	a. Horn switch or its circuit connection failure b. Horn failure c. Fuse failure	1) Check the horn button and its connection circuit; 2) Check the horn and its connection circuit; 3) Check fuse and its connection circuit;

Carry out troubleshooting in accordance with the order listed in the table, it can help you quickly identify problems and resolve accordingly.

- To provide targeted and rapid response to faults, the following details are useful and important to provide for the customer service department:
- Truck serial number
- Display unit error number (if present)
- Error description
- Current location of truck.

**APPENDIX**

**I Lithium battery operating instructions**

## 1.1 Lithium Battery Use and Maintenance Manual

### ➤ Information on the conformity of lithium-ion batteries

The manufacturer of the lithium-ion battery and EP group provider declares that: the lithium-ion battery conforms with the provisions of the following EU directive 2014/30/EU in accordance with EN12895.

This declaration of conformity with EU directives applies only to battery use that conforms to the recommendations described in the operating instructions.

### ➤ Special lithium-ion safety rules



#### **DANGER**

*There is a risk of fire.*

Use water-based extinguishers, CO<sub>2</sub>, dry chemical fire extinguishers.



#### **DANGER**

*Electrical danger*

*Do not open the battery. Electrical risk.*

*Only the After-Sales Service Centre technicians can open the battery.*

#### **It is necessary to respect the following guidelines:**

- Read the documents provided with the battery carefully.
- Only persons who have been trained to work with lithium-ion technology are permitted to work on the batteries (for example After-Sales Service Centre technicians).
- Do not place lithium-ion batteries on or near flames or hot heat sources (> 65°C). This may cause the batteries to overheat or burst into flames. This type of use also impairs the performance of the batteries and reduces their service life.
- Improper use may cause overheating or serious injury. Respect the following safety rules:
  - Never short circuit the battery terminals
  - Do not reverse the battery polarity
  - Do not open the battery
  - Do not submit the battery to excessive mechanical constraints

### ➤ Intended use

- Operational application temperature 0° C-40° C, humidity < 80%;
- Charging application temperature 5° C-40° C;
- The battery's maximum operation altitude is up to 2000m;
- Do not disconnect the battery for emergency stopping, use instead the emergency switch.
- The truck shall not be used in a potentially explosive atmosphere or in an especially dusty environment.

### ➤ Reasonably foreseeable misuse

- Never short circuit the battery terminals.
- Do not reverse the battery polarity.
- Do not overcharge.

➤ **Accessories**

*Do not use a charger that is not released by your manufacturer for lithium-ion battery.*

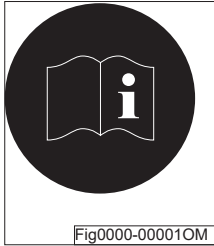
➤ **BMS (Battery Management System)**

The battery is permanently monitored by the BMS (Battery Management System).

This provides the communication with the truck.

The BMS continually monitors items such as the cell temperature, the voltage and the charge status of the cells.

**1.2 Safety and warning**



- Abide by the operation manual!
- All the operations related to the battery must be implemented under the instruction of professionals!



Always wear protective clothing (e.g. safety goggles and safety gloves) when working on cells and batteries.



- No smoke and fire!
- Avoid the existence of open fire, fiery metal wire or sparks around the battery, otherwise explosion or fire disaster may occur!



Don't trample on the battery to prevent it from fierce shaking or shacking!



Do not place the battery on top of conductive objects.



Fig0000-00004OM

- Explosion or fire disaster is likely to occur; avoid short circuit!
- Keep the battery away from all fire sources, heat sources and flammable or explosive materials.



Fig0000-00005OM

- Don't knock over the storage battery!
- Using lifting and delivery devices as specified. Prevent the storage battery cell, interface and connection cable from being damaged by the lifting hook!
- If the materials leak out, do not inhale the fumes. Wear safety gloves.

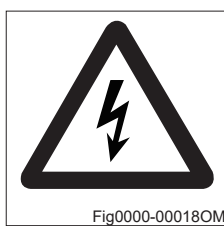


Fig0000-00018OM

- Dangerous voltage!
- Avoid hot plugging!
- Notice: the metal part of the storage battery cell is electrified, so don't place any external object or tool on the battery cell!



Fig0000-00019OM

Keep the battery away from all fire sources, heat sources and flammable or explosive materials.



Fig0000-00020OM

Avoid the battery becoming corroded by water or corrosive liquid.



## WARNING

- Battery life will be shortened if the battery is used for a long time at low temperature or stored.
- Only temporary cold store application permissible as the permissible battery operating temperature is between 0°C and 40°C



### 1.3 Hazard of faulty or discarded battery

Please monitor the battery status when in use and in storage. If you find any broken batteries, electrolyte leakage, abnormal expansion or pungent odors due to shipping damage or abnormal vibration, please stop use immediately and keep at least a 5 meter perimeter around the effected batteries. Please dispose of the damaged batteries properly and contact a recycling company to recycle the batteries. For batteries that are under EP warranty policy, EP will access the warranty claim according to your submission of the battery nameplate photo .

During the period waiting for disposal or recycle, please stock damaged and old batteries carefully by following instructions:

1.Damaged and discarded battery temporary storage needs to be placed in an iron or plastic container with water that can cover whole battery at least 5 days (The battery may emit smoke when immersed in water. This is the process of consuming energy by the leaking battery, which is a normal reaction).

- Keep the container and batteries outdoors and 5 meters away from other things, especially flammable items.
- Use protective gloves when putting batteries in or out of water.
- Do not stack damaged or old batteries.

2.For big battery with inner and outer boxes structure, Keep the batteries outdoors at least 5 days. and contact a recycling company to recycle the batteries.



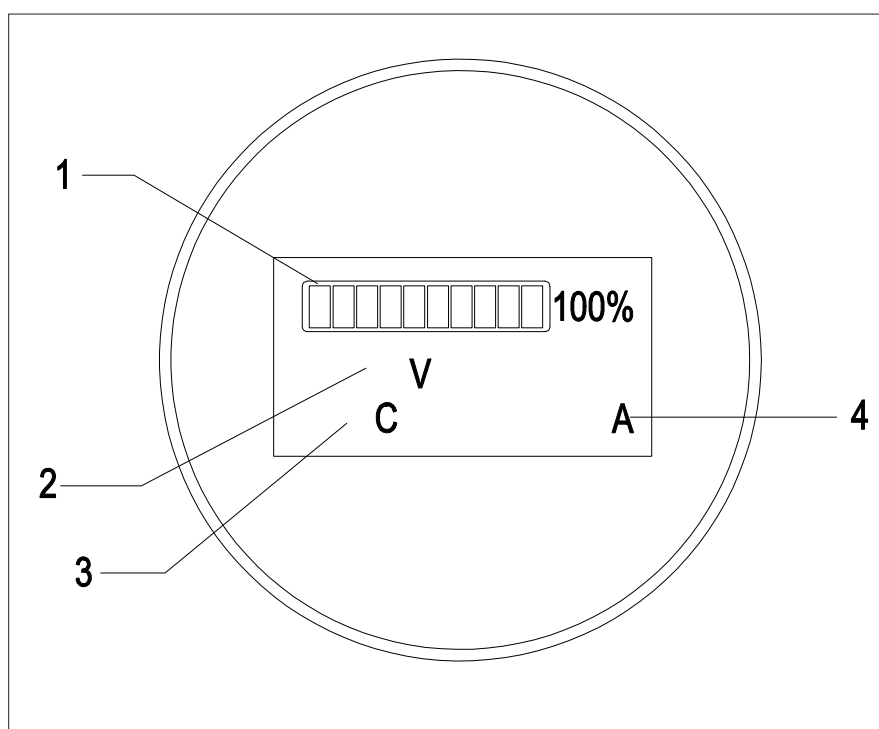
#### **WARNING**

1. *Do not store the battery for a long time;*
2. *No load bearing, squeezing and contact stacking when storing the batteries;*
3. *Do not place the batteries near cargo warehouses or near flammable and explosive dangerous goods.*

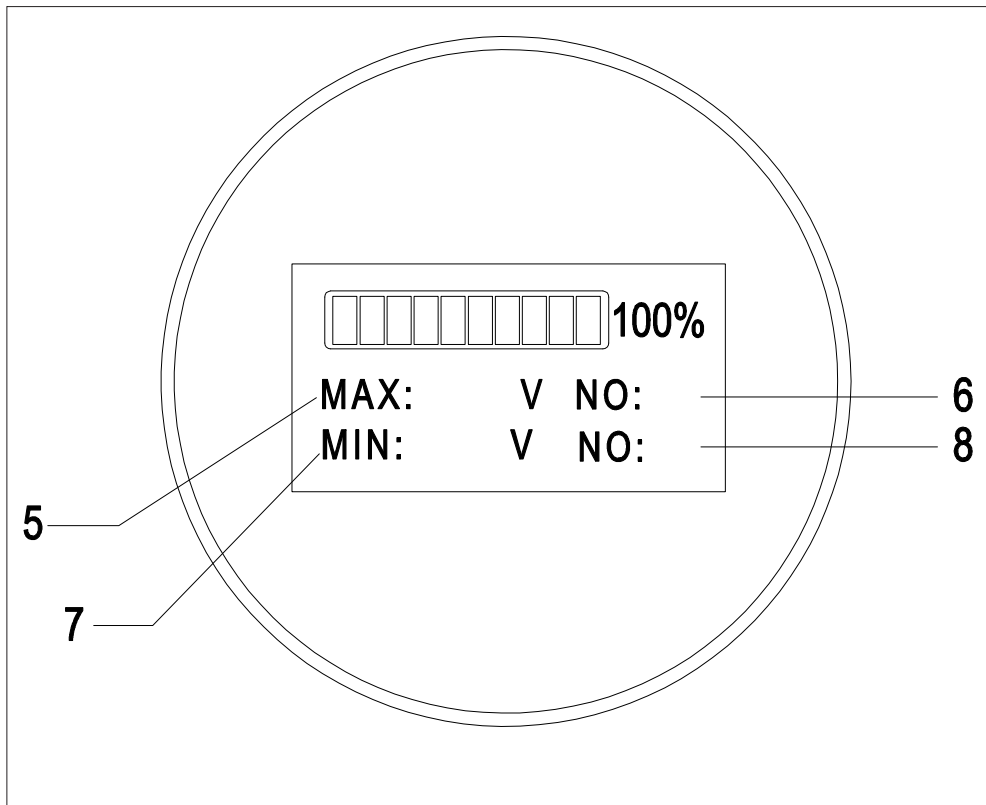
## 1.4 Instructions

- Before the first use, charge battery completely with original charger.
- The lithium battery should be used at an ambient temperature of 0 ~ 40°C, do not use or store the battery near a fire source/heat source where the temperature exceeds the safety range;
- When the battery is low, please charge the battery in time to avoid over-discharge; the replaced battery should also be charged in time to avoid damage caused by over-discharge of the battery after self-discharge.
- Do not place metal objects (such as wrenches, knives) on the lithium battery, or other objects that may cause short-circuiting of the battery to avoid short circuit between the positive and negative terminals;
- Do not bump or strike the lithium battery during use, If leakage is found on the battery, stop using it right away, pull out all the plugs connected to it, place it in open and well-ventilated space, and contact the after-sales service.
- If the battery life is significantly shortened, please contact the after-sales for check;
- If the lithium battery fails and cannot be used, please remove the battery from the material handling equipment, the trained personnel can use our BMS special reading instrument to read the information for preliminary judgment; for problems that cannot be solved, please contact the after-sales service department for solutions;
- Before installing and removing the battery, be sure to read the user manual; the weight of the battery body is evenly distributed, please pay attention to the installation and removal when there is an external weight; please use two hooks to hang on the lifting rings during the lifting process, and gently lift it to keep it stable and not inclined;
- The operator must read the instructions carefully before use and receive relevant safety training to be able to handle emergencies;

### 1.4.1 Battery indicator

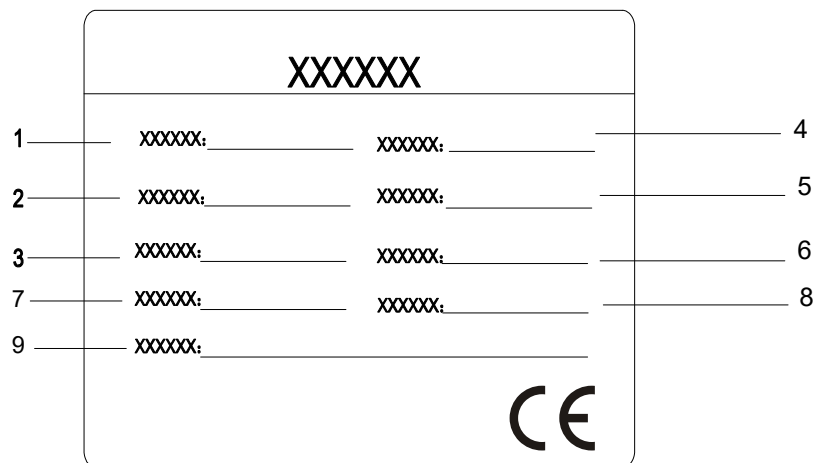


No.	Name	Description
1	Energy display	When all 10 cells are on, it indicates that the battery is full; When the first cell and the second flash alternately, it indicates that the battery is low and must be charged. The battery remaining charge is displayed; "100%" indicates that the battery is fully charged.
2	Total voltage	The sum of the total voltages of the lithium battery series
3	Temperature	Battery temperature
4	Charging current	Current value when charging the lithium battery



No.	Name	Description
5	Maximum cell voltage	Maximum value of cell voltage
6	No. of cell	Identification No. of the cell with maximum voltage.
7	Minimum cell voltage	Minimum value of cell voltage
8	Cell No. of minimum cell voltage	Identification No. of the cell with minimum voltage.

### 1.4.2 Lithium Battery Nameplate



No.	Name	No.	Name
1	Battery model	4	Cell Type
2	Nominal Voltage	5	Nominal Capacity
3	Nominal Energy	6	Version NO.
7	Battery Weight	8	Date
9	Serial No.		

### 1.4.3 Charging

- This battery can only be charged with the vehicle-specific charger, other chargers may cause battery damage.
- The normal charging temperature range of the battery is: 5°C ~ 40°C, please do not charge in the environment beyond the normal temperature range;
- If the battery is not fully charged in specified time, check the max. voltage of the cells of the battery, if it is higher than 3.65V, stop charging it immediately, and contact the after-sales service.
- During the charging operation, it is necessary to have professional personnel to operate and care, in order to ensure that the charging plug and socket work normally without heat, to ensure that the charging device works normally, to ensure that the battery pack and its protection circuit work normally, and the whole power supply system has no sign of short circuit, over current, over temperature or overcharge.
- When charging, connect the battery to the charger; after starting charging, the circular display meter will display the total voltage, the maximum and minimum cell voltages, power, temperature, charging current and other information; pay particular attention to the charging current and the maximum and minimum cell voltages, as well as the voltage difference between them; if there is abnormality, stop charging in time and contact the after-sales service department for solutions.
- Charging in non-charging area is prohibited;
- No modification of vehicles;
- Do not use irregular charging sockets;
- The net height of the charging area shall be higher than 5m, and the safe distance from other areas shall be greater than 5m.



#### **WARNING**

*Lithium batteries are strictly prohibited from overcharging and over discharging.*



#### **CAUTION**

1. *The normal charging temperature range of the battery is: 5°C~40°C.*
2. *The voltage difference between the maximum and minimum cell voltages during charging is less than 0.1V.*
3. *The lithium battery voltage matches the charger voltage.*
4. *The charger should be periodically checked for charging over voltage protection device.*

#### ➤ **Charging procedure:**

- Move the truck close to the charger, turn off the key switch;
- Before charging, make sure the voltage of the battery matches that of the charger;
- Connect the charger and the battery;
- Check whether the data displayed on the indicators of charger and battery is normal or not;

## 1.5 Storage

- Try to ensure that the battery or battery pack's power is  $\geq 50\%$  before long-term storage as the battery has the function of self-discharge, be sure to charge the battery once every 2 months to ensure the battery power is  $\geq 50\%$ ;
- The battery should be stored in a temperature environment of  $0^{\circ}\text{C}\sim 40^{\circ}\text{C}$ ;
- The battery in a dry, ventilated and cool environment, avoid direct sunlight, high temperature, high humidity, corrosive gas, severe vibration, etc.
- DO NOT stack, stacking of the batteries is not allowed.
- Disconnect the batteries from other electrical items before storage, it is prohibited to have any form of discharge behavior during storing;
- If the battery is found to be bulged, cracked, or has a low voltage value after long-term storage, the battery may be damaged; please contact the relevant technical department of the company for technical support.
- After not using the battery for a long time, do not charge or discharge the battery if the smell of leakage is found near the battery.



### WARNING

1. Dispose of used batteries in time;
2. Do not store used batteries for a long time.
3. No load bearing, squeezing and contact stacking when storing batteries;
4. Do not place batteries near cargo warehouses or near flammable and explosive dangerous goods.


## 1.6 Transportation

Before transporting any lithium-ion battery, check the current regulations on the transport of dangerous goods. Comply with these when preparing the packaging and transport. Train authorised staff to dispatch lithium-ion batteries.



### NOTE

Recharge the lithium-ion battery before transporting it taking account of the transport mode (boat, road). Excessive discharge on arrival could damage the performance of the battery.

<b>For UN3480</b>	Lithium-ion Batteries	 Fig0000-000800M
<b>For UN3481</b>	Lithium-ion Batteries packed with Equipment or Lithium batteries built into Equipment	

### ➤ Shipping faulty batteries

To transport these faulty lithium-ion batteries, contact the manufacturer's customer service department. Faulty lithium-ion batteries must not be transported independently.

**i** NOTE

*It is recommended that the original packaging is kept for any subsequent dispatch.*

*A lithium-ion battery is a special product.*

*Special precautions should be taken when:*

- *Transporting a truck equipped with a lithium-ion battery*
- *Transporting only the lithium battery*

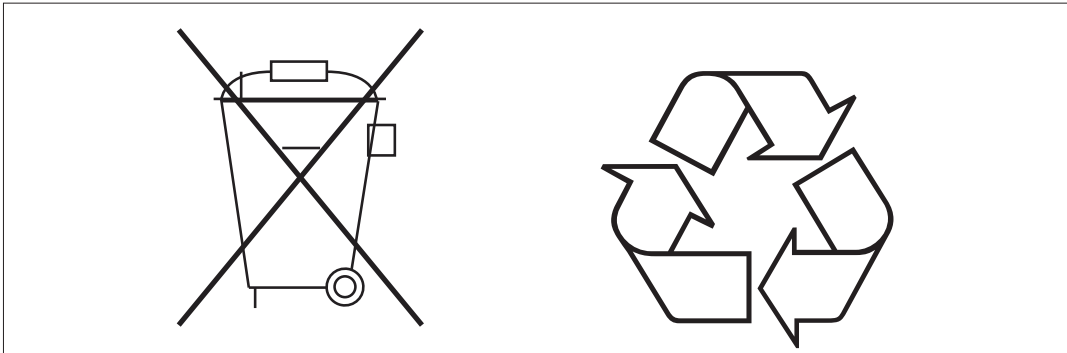
*A class 9 danger label must be affixed to the packaging for transport.*

*It is different if the battery is transported on its own or in a truck. An example of a label appears in this supplement. Refer to the latest current regulations before dispatch as the information might have changed since this supplement was written.*

*Special documents must be sent with the battery. Refer to the applicable standards or regulations.*

### 1.7 Instructions for disposal

- Lithium ion batteries must be disposed of in accordance with the relevant environmental protection regulations.
- Used cells and batteries are recyclable economic goods. In accordance with the mark showing a crossed rubbish bin, these batteries may not be disposed of as domestic waste. Return and / or recycling must be ensured as required by the Batteries Legislation.
- The method of battery recovery and reuse can be discussed with our company. We reserve the right to change the technology.



➤ **The requirements of recycling**

1. Only authorized EP dealers who have attended the after sales training, are authorized to do repairs on EP batteries;
2. All Li-ion battery should be placed in safe place according to the EP Li-ion battery Manual;
3. The transport of Li-ion battery must meet local regulation, EP will supply UN38.3 and MSDS files according with UN and ADR regulation;
4. The package of Li-ion battery before delivery must meet the UN 3480 or local carrier regulation.



## WARNING

*Don't bump, handle gently.*

*Used cells and batteries are recyclable economic goods. In accordance with the mark showing a crossed rubbish bin, these batteries may not be disposed of as domestic waste. Return and / or recycling must be ensured as required by the Batteries Act (Act regarding the commissioning, return and environmentally responsible disposal of batteries and accumulators). For battery disposal please contact the manufacturer's customer service department.*

### 1.8 Common Problems and Solutions

During the use and maintenance of the lithium-ion battery, the battery or battery system may have one or more of the following abnormal conditions, please organize the professional engineers and technicians to perform the necessary processing according to the instructions in this manual; if you have any questions about the status or solutions, please contact your dealer or after-sales service department of the company to obtain professional technical support.

- If the battery is found to have abnormal mechanical characteristics such as swelling, cracked casing, melted casing deformation, and distortion of the casing before and during installation, stop using the battery immediately and store it separately;
- If abnormalities such as looseness, cracks, in the insulation layer, burn marks, etc. of the battery's pole pressing bolts, conductive strips, main circuit wires and connectors are found before and during the installation, stop using the battery immediately, check the reason for analysis and give it a fix;
- If the polarity of the positive and negative terminals of the battery is found not match the polarity identification before installation, please stop using the battery immediately and contact the after-sales service department to replace the battery or obtain other solutions;
- If the temperature of the battery exceeds 65°C before and during installation, stop using the battery immediately and leave it separately, if the temperature continues to rise, it needs to be buried with sand;
- If there is fire or smoke happens to the battery, move it to the open air immediately, evacuate people in time, and contact a recycling company to recycle the batteries.



## 1.9.Service Daily Maintenance

No.	Maintenance content	Method of operation	Note	Frequency
1	Check if battery capacity is too low	Check instrumentation SOC display	Make sure the battery is not stored without charge for a long time. If the battery system needs to be put on hold for a long time, it is best to keep the battery in half power state and charge the battery every 3 months to ensure that the battery system is in half power state.	Everyday
2	The battery pack charge and discharge current	Check instrumentation display	make sure battery pack charge and discharge current meet with operation manual	Everyday
3	Connector pins at the bottom of the battery(if necessary)	Perform a visual inspection	If any ablation or deformation occurs in daily inspection, the battery connector pins should be replaced in time.	Everyday
4	Check whether the appearance is deformed, whether the surface is oxidized, paint removing, the mounting position is offset, and the cabinet is damaged;	Perform a visual inspection	check the reason for analysis and give it a fix	Everyday
5	Check the entire battery as well as the surface beneath it for signs of fluid leakage.	Perform a visual inspection	check the reason for analysis and give it a fix	Everyday
6	Clean the lithium battery and charger with a dry cloth or compressed air.	Perform a visual inspection, Wear insulated gloves and shake it gently	Make sure it tight	weekly

No.	Maintenance content	Method of operation	Note	Frequency
7	Whether the external wiring harness has worn, imprint, creases and exposed line core	Perform a visual inspection	Make the wiring harness fixed well	weekly
8	Check that the surface of lithium-ion battery looks clean	No dust, no water, no corrosion, oxidation, rust, etc.	Clean surface if you found dust, corrosion, oxidation, rust by using dustless cloth or air compressor ,water battery is strictly prohibited to use	weekly
9	Check that the outside screws of the battery are fastened	Torque wrench correction requires no loosening	Reinforce screws	weekly
10	Check for water or foreign matter in the plug and socket and check for rust or charring(if necessary)	Perform a visual inspection	check the reason for analysis and give it a fix	Monthly
11	Check the cable for damage and loose joints(if necessary)	Perform a visual inspection	check the reason for analysis and give it a fix	Monthly
12	Check the battery case for abnormalities such as cracks, deformation, and bulging.	Perform a visual inspection	check the reason for analysis and give it a fix	Monthly



#### **NOTE**

*The EP instrumentation is used for serviced.*

#### ➤ **Cleaning**

The manufacturer recommends to only use compressed air at less than 207 kPa (30 psi) or a slightly damp towel to clean the battery. The battery, or its charging station, may be equipped with fans, heat sinks, or other cooling devices that require periodic cleaning. Always know and follow the battery manufacturer's recommendations for cleaning and service.

#### ➤ **Optimize Battery Life**

Always use and follow the battery management system (BMS). The BMS is the electronic system that monitors battery data and use that data to its operating environment to influence the battery's safety, performance, and service life. It also functions as a safety cut-off device in case of overcharging, overcurrent, or overheating. Lithium-ion battery life is greatly reduced if used outside a temperature range of 0°C to 40°C (32°F to 104°F) or in an environment with greater than 85% humidity. EP recommends to opportunity charge lithium-ion batteries. This is when the battery is recharged for short intervals during a shift period. It reduces or eliminates the need for long charging periods, changing batteries during a shift, and extending shift periods.