

印中力

CQE12/15S

Reach Truck

Operation Manual

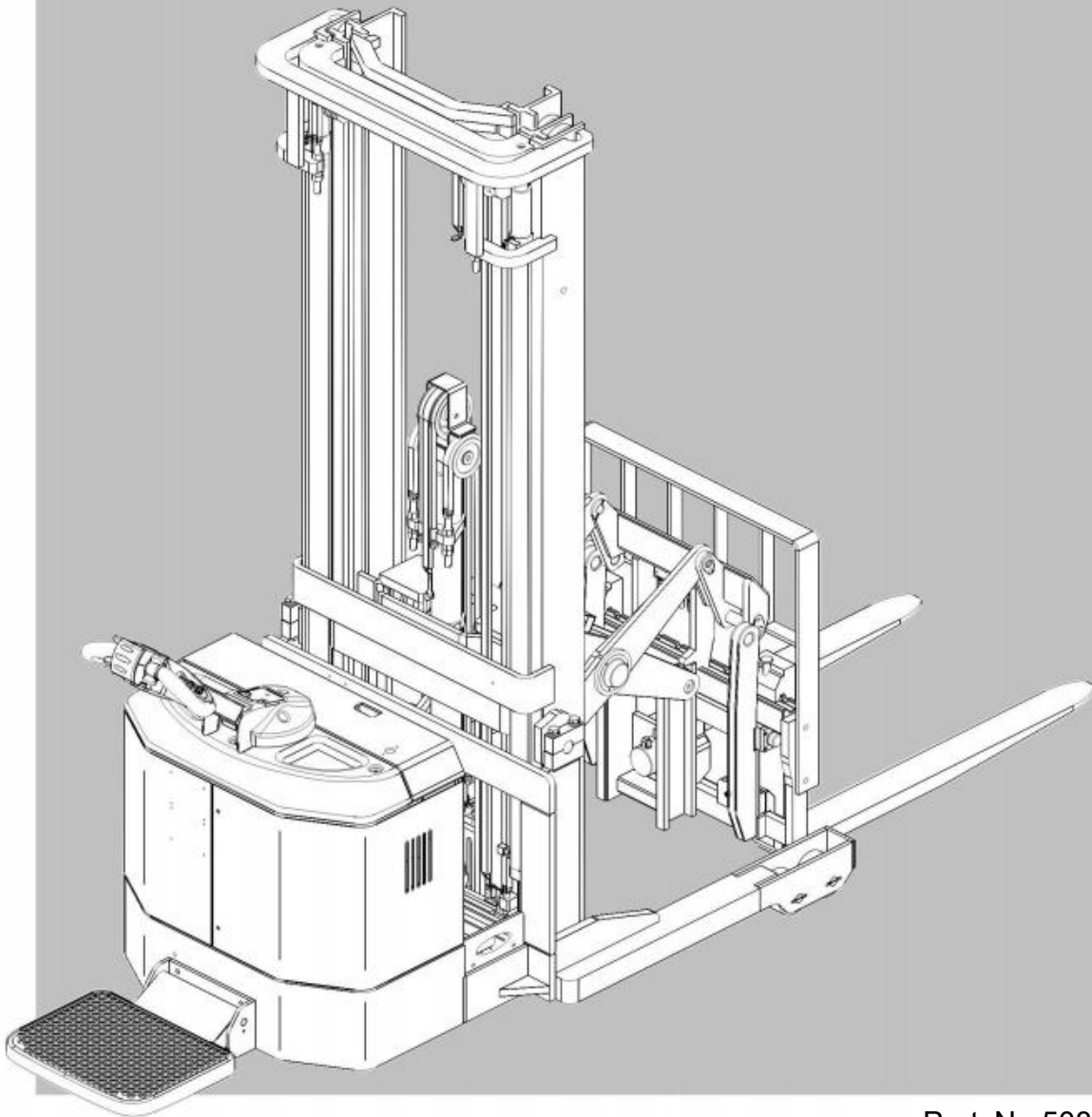

Part No.50800003121
V1 08/2019



EP EQUIPMENT CO.,LTD. is one of the world's leading companies manufacture, design material handling equipment and provide related service. With over 100,000m² plant it produces over 100,000 trucks per year, and provides professional, effective and optimized material handling solutions worldwide, until now it has developed three major kinds of business:

- Material handling equipment: Focus on electric forklift and warehouse equipment
- OEM parts: Global parts supply
- Imow industry,online: One stop industrial products supply

Guided by our customer-oriented concept, EP has developed service centers in more than 30 countries around the world, from which customers are able to receive timely local service. Moreover, 95% of warranty parts can be shipped out within 24 hours after been ordered. Through our online after-sales service system, customers can process their warranty claims, order spare parts and consult the operation manuals, maintenance materials and spare parts

catalogs.

With business all over the world, EP has thousands of employees and hundreds of agents worldwide to provide our global customers with prompt local service.

Based on the concept of sharing economy , EP also offer rental service for various logistics equipment. Adhering to the idea “Making the leasing of logistic equipment more simple”, EP is devoted to providing customized one-stop leasing solutions for our customers with our high quality, reasonable price and prompt rental service.

EP's mission&vision is “ Let more people apply the electrical material handling equipment to relieve the intensity of labour” and “Let's grow together” .

EP EQUIPMENT CO., LTD
Address: XIAQUAN, DIPU, ANJI,
ZHEJIANG, CHINA
Tel: + 86-0571-28023920
Fax: + 86-0571-28035616
Website: www.ep-ep.com
Email: service@ep-ep.com

Foreword

The present original operating instructions are designed to provide sufficient instruction for the safe operation and maintenance of the Reach Truck. Please be sure to read this operator manual carefully if you are operator or are in charge of the Reach Truck, before you operate and service the Reach Truck. Only in this way can you protect yourself and make the Reach Truck play a role as much as possible.

Our Reach Trucks are subject to ongoing development, so maybe there are some differences between your product and the description in this manual. And the operator manual details will be different because of customer's special requirements.

If you have any questions ,please keep in touch with the sales department or let the dealer know.

Notes:

1. This manual is used for operation and maintenance , the detail parameters, size and specifications in context is only for reference , the real parameters will depend on sale files.
2. Manual pictures for reference only, the real car shall prevail, and shall not affect the manual use.
3. Manual pictures only sign for one of the models in this series models.

Internet address and QR code of Parts manual

By entering the address <http://www.ep-care.com> in a web browser or by scanning the QR code, Login after registration, Select "Parts purchase" function and input part number or model name to find the truck.



Note: After registration, please send email to info@ep-care.com to activate your account

COPYRIGHT OF THESE OPERATING INSTRUCTIONS REMAINS WITH EP
CO.,LTD

OM2412 08.19

WARNING!
TO PREVENT SETIOUS RISK OF INJURY TO
YOUORSELF AND OTHERS OBSERVE THE
FOLLOWING SAFETY INSTRUCTIONS.

These Reach Truck may become hazardous if adequate maintenance is neglected. Therefore, adequate maintenance facilities, trained personnel and procedures should be provided.

Maintenance and inspection shall be performed in conformance with the following practices:

1. A scheduled planned maintenance,lubrication and inspection system should be followed.
2. Only qualified and authorized personnel shall be permitted to maintain, repair, adjust, and inspect Reach Truck.
3. Before leaving the Reach Truck:
 - Do not park the Reach Truck on an incline.
 - Fully lower the load forks.
 - Press the emergency brake switch .
 - Set the key switch to the "OFF" position and remove the key.
4. Before starting to operate Reach Truck:
 - Be in operating position
 - Place directional control in neutral
 - Before operating Reach Truck, check functions of lift systems, directional control,speed control,steering, warning devices and brakes.
5. Avoid fire hazards and have fire protection equipment present. Do not use open flame to check lever, or for leakage of electrolyte and fluids or oil. Do not use open pans of fuel or flammable cleaning fluids for cleaning parts.
6. Brakes,steering mechanisms, control mechanisms,guards and safety devices shall be inspected regularly and maintained in legible condition.
7. Capacity, operation and maintenance instruction plates or decals shall be maintained in legible condition.
8. All parts of lift mechanisms shall be inspected to maintain them in safe operating condition.
9. All hydraulic systems shall be regularly inspected and maintained in conformance

with good practice. Cylinders, valves and other similar parts shall be checked to assure that "drift" has not developed to the extent that it would create a hazard.

10. Reach Truck shall be kept in a clean condition to minimize fire hazards facilitate detection of loose or detective parts.

11. Modifications and additions which affect capacity and safe Reach Truck operation shall not be performed by the customer or user without manufacturers prior written approval. Capacity, operation and maintenance plates or decals shall be changed accordingly.

Catalog

Correct use and Application.....	1
1. Reach Truck Description.....	2
1.1 Application.....	2
1.2 Reach Truck Assemblies.....	3
1.2.1 Control Handle.....	4
1.2.2 Key switch.....	4
1.2.3 Battery discharge indicator.....	5
1.3 Standard Version Specifications.....	6
1.3.1 Performance data for standard Reach Trucks.....	6
1.3.2 Dimensions.....	6
1.4 Identification points and data plates.....	11
1.4.1 Reach Truck data plate.....	12
1.4.2 Capacity chart.....	13
2. Commissioning.....	14
2.1 Using the Reach Truck for the First Time.....	14
2.2 During brake-in.....	14
3. Operation.....	15
3.1 Safety Regulations for the Operation of Reach Trucks.....	15
3.2 Operate and run the Reach Truck.....	16
3.2.1 Preparing.....	16
3.2.2 Travel, Steering, Braking.....	16
3.2.3 Lifting, transporting and depositing loads.....	18
3.2.4 Parking the Reach Truck securely.....	19
4. Battery Maintenance & Charging.....	20
4.1 Safety regulations for handling acid batteries.....	20
4.2 Battery type & dimension.....	20
4.3 Charging the battery.....	21
4.4 Battery removal and installation.....	21
4.5 Battery maintenance.....	22
4.6 Battery Disposal.....	22
5. Reach Truck Maintenance.....	23
5.1 Operational safety and environmental protection.....	23
5.2 Maintenance Safety Regulations.....	23
5.3 Servicing and inspection.....	24
5.3.1 Maintenance Checklist.....	25
5.3.2 Lubrication Schedule.....	26
5.3.3 Maintenance Instructions.....	27
5.4 Decommissioning the Reach Truck.....	29
5.4.1 Prior to decommissioning.....	29

5.4.2 Restoring the Reach Truck to operation after decommissioning.....	30
5.5 Safety checks to be performed at regular intervals and following any unusual incidents.....	30
5.6 Final de-commissioning, disposal.....	30
6.Troubleshooting.....	31
6.1 Error Message.....	32

Correct use and Application

The Reach Truck described in the present operator manual is an industrial Reach Truck designed for lifting and transporting load units.

It must be used, operated and serviced in accordance with the present instructions. Any other type of use is beyond the scope of application and can result in damage to personnel, the Reach Truck or property. In particular, avoid overloading the Reach Truck with loads which are too heavy or placed on one side. The data plate attached to the Reach Truck or the load diagram are binding for the maximum load capacity. The Reach Truck must not be used in fire or explosion endangered areas, or areas threatened by corrosion or excessive dust.

Proprietor responsibilities

For the purposes of the present operator manual the “proprietor” is defined as any natural or legal person who either uses the Reach Truck himself, or on whose behalf it is used. In special cases (e.g. leasing or renting) the proprietor is considered the person who, in accordance with existing contractual agreements between the owner and user of the Reach Truck, is charged with operational duties.

The proprietor must ensure that the Reach Truck is used only for the purpose it is intended for and that danger to life and limb of the user and third parties are excluded. Furthermore, accident prevention regulations, safety regulations and operating, servicing and repair guidelines must be followed. The proprietor must ensure that all Reach Truck users have read and understood this operator manual.

Failure to comply with the operator manual shall invalidate the warranty. The same applies if improper work is carried out on the Reach Truck by the customer or third parties without the permission of the manufacturer’s customer service department.

Adding accessories

The mounting or installation of additional equipment which affects or enhances the performance of the Reach Truck requires the written permission of the manufacturer. Local authority approval may also need to be obtained.

Local authority approval does not however constitute the manufacturer’s approval.

1. Reach Truck Description

1.1 Application

The Reach Truck is reach electric Reach Truck with a steered drive wheel.

It is designed for use on level floors to lift and transport palletised goods. Open bottom pallets or roll cages can be lifted.

The capacity can be obtained from the data plate.

The capacity with respect to lift height and load center of gravity is indicated on the capacity plate.

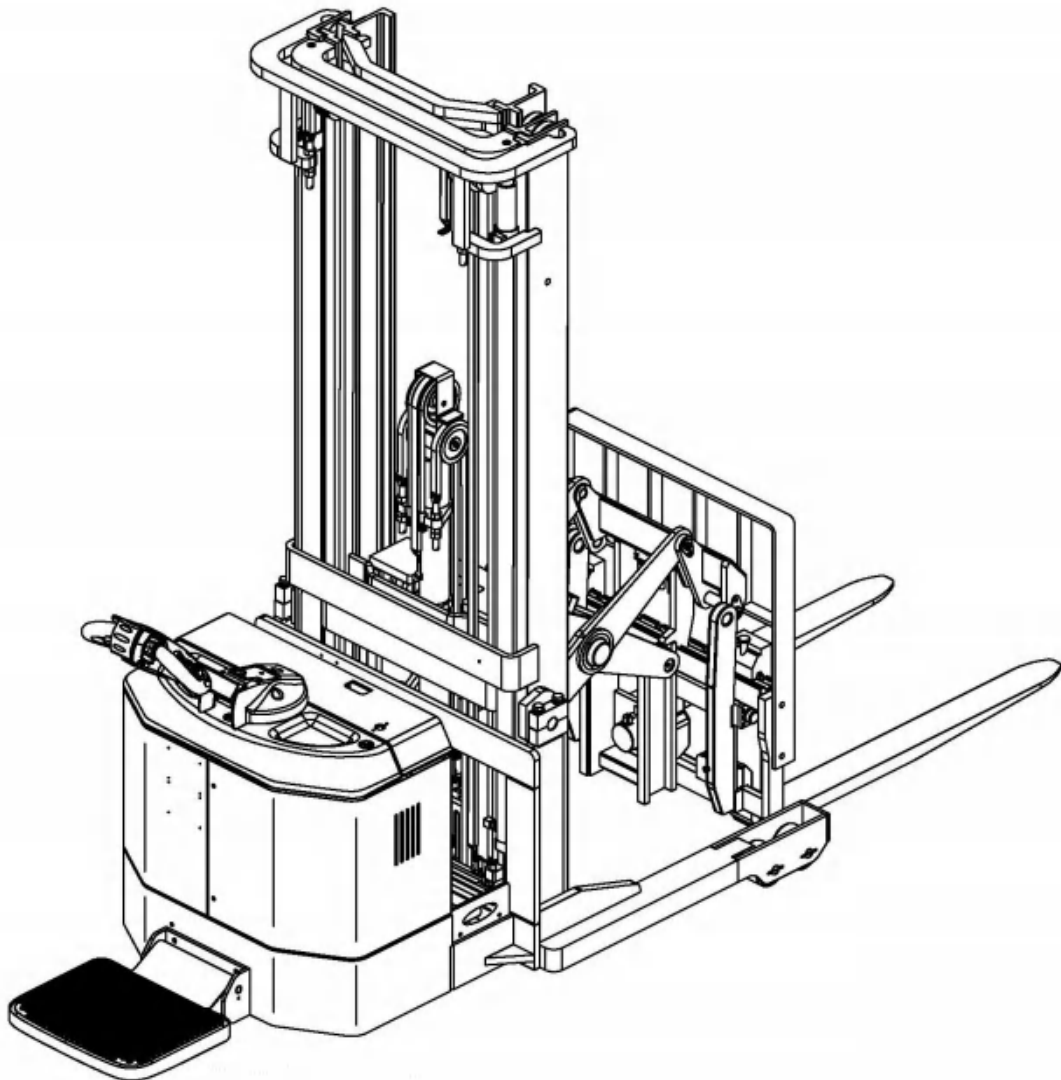

1.2 Reach Truck Assemblies

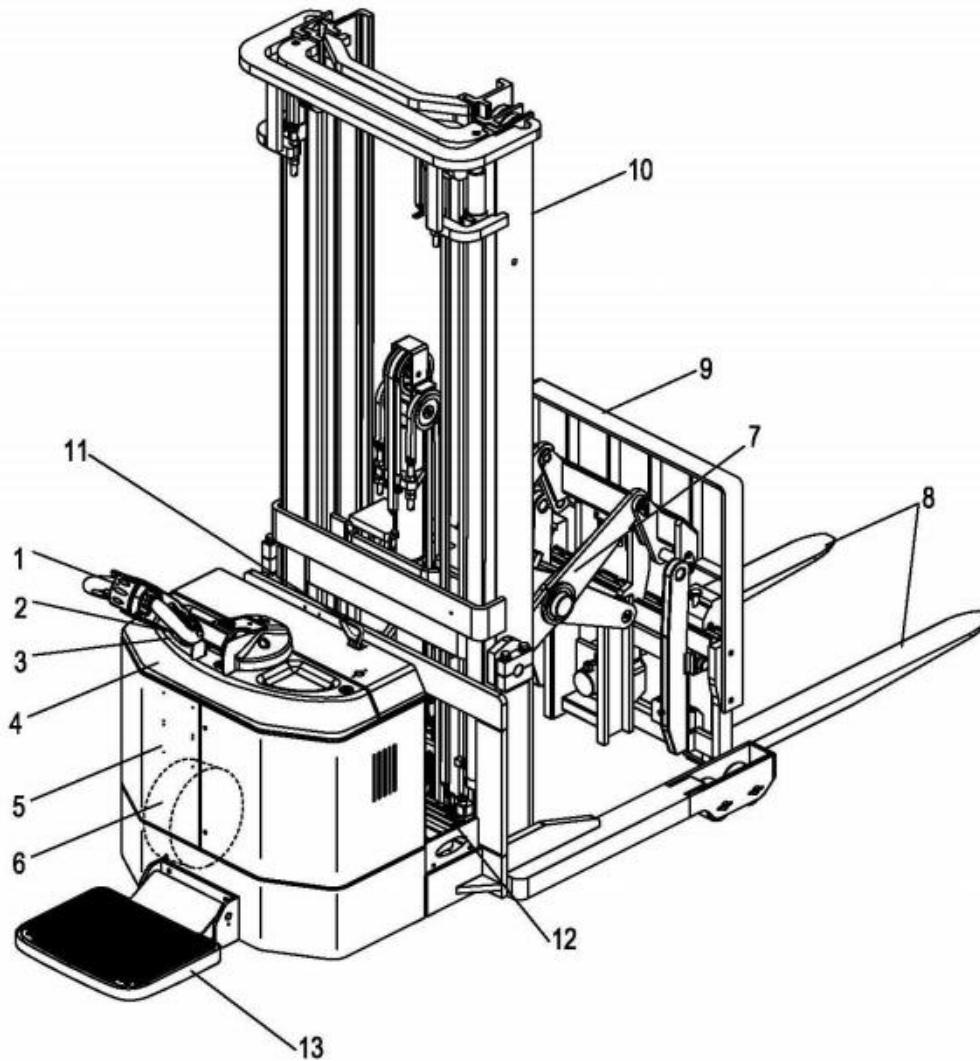

Item	Component	Item	Component
1	Control shaft with control shaft head Drive wheel	8	Lifting device
2	Key switch	9	Blocking Shelf
3	Combined instrument (battery discharge monitor and operating hour meter)	10	Hoist frame
4	Up Cover	11	Plug
5	Rear Cowl	12	Battery
6	Driving Wheel	13	Pedal (CQE12 Optional)
7	Scissors	13	Pedal (CQE15S)

1.2.1 Control Handle

Item	Component	Function
14	"Tilting backward&forward" button	Tilting the mast backward or forward
15	"Reach backward&forward" button	Reach the mast backward or forward
16	"Lower&Lift" switch	Lowers or Raises load forks.
17	Sides way Switch	Sides way the fork
18	Warning signal button	Triggers a warning signal.
19	Collision safety switch	Safety function which, when activated, forces the Reach Truck to reverse until the switch restored to neutral.
20	Travel switch	Controls the driving speed and direction

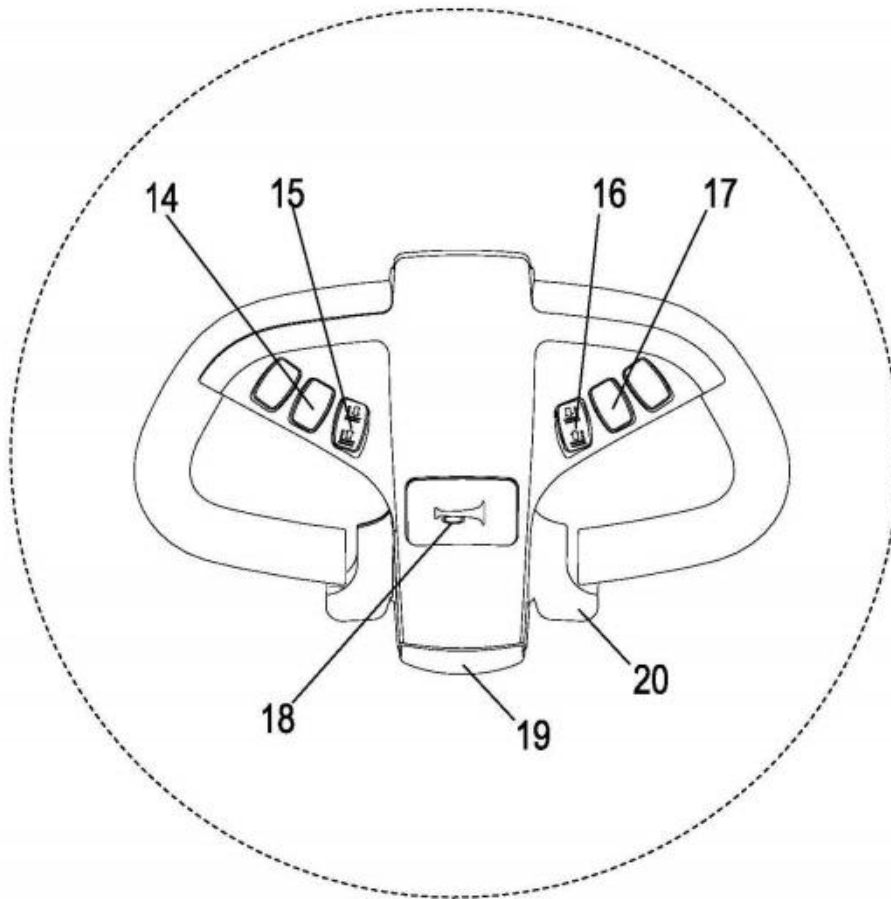

1.2.2 Key switch

Switches control current on and off.
 Removing the key prevents the Reach Truck from being switched on by unauthorised personnel.

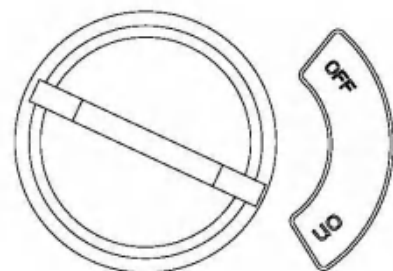

1.2.3 Battery discharge indicator

The LEDs (1) represent battery residual capacity, The LCD (2) displays the operating hours.

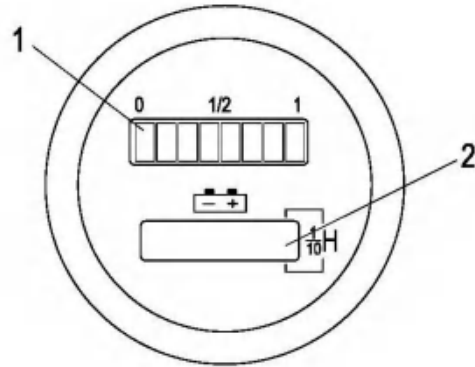

Battery Discharge Indicator(1)

When the Reach Truck has been released via the key switch, the battery charge status is displayed.

The colours of the LEDs (1) represent the following conditions:

Component	LED colour	value
Standard battery residual capacity	Green	70-100%
	Orange	50-60%
	Flashing Red	0-20%

Battery Discharge for 70%, A flashing red show on storage battery charge warning.

Battery Discharge for 80%, Two flashing reds show on battery charge used up warning, Lifting is now inhibited. The battery must be charged.

Operating hours display(2)

Display range between 0.0 and 99,999.0 hours. Travel and lifting are logged. This is a backlit display.

Power up test

On power up the display shows:

- the operating hours
- the charge status

1.3 Standard Version Specifications

Technical specification details in accordance with VDI2198. Technical modifications and additions reserved.

1.3.1 Performance data for standard Reach Trucks

Item	Description	CQE12	CQE15S	Unit	
	Drive unit	Battery	Battery		
	Operator type	pedestrian	standing		
Q	Load capacity	2645	3300	lb.	
c	Load center	23.6	23.6	in.	
	Travel speed, laden/ unladen	3.4/3.7		mph	
	Lifting speed, laden/ unladen	17.7/26.6		fpm	
	Lowering speed, laden/ unladen	31.5/29.5		fpm	
	Reaching speed, laden / unladen	15.7/15.7		fpm	
	Maximum gradeability, laden/ unladen	6/10		°	
	Service weight (Duplex Mast,With battery)	4045	4110	lb.	
	Loadin g	Unladen, Front / Rear, fork	2510/1535	2535/1575	lb.
		Unladen, Front / Rear, fork retracted	2730/1315	2755/1355	lb.
		Laden, Front / Rear, fork advanced	630/6060	685/6730	lb.
		Laden, Front / Rear, fork	2065/4625	2370/5045	lb.
	Drive motor rating S2 60 min.	1.7/2	4.4	kW	
	Lift motor rating at S3 15%	4		kW	
	Battery voltage/ rated capacity (5h)	24/210	24/280	V/Ah	
	Battery weight	418.9	507	lb.	

1.3.2 Dimensions

Item	Description	CQE12	CQE15S	Unit
y	Wheelbase	53.7		in.
h ₁	Height, mast lowered	82.3		in.
h ₂	Free lift	0		in.
h ₃	Lift height	118.1		in.
h ₄	Height, mast extended	155.9		in.
h ₇	Seat height/standing height	--	5.9	
h ₈	Height of wheel arms	5.3	5.3	in.
l ₁	Overall length	86.3	90.5	in.
l ₂	Length to face of forks	44.1	48.4	in.
b ₁ / b ₂	Overall width	33.5/43.3		in.
s/e/l	Fork dimensions	1.5/3.9/42.1		in.

b ₃	Fork Frame width	31.5		in.
b ₅	Distance between fork-arms	7.8-30.7		in.
b ₄	Distance between wheel arms/loading surfaces	35.4		in.
α/β	Tilt of mast/fork carriage forward/backward	2/4		°
l ₄	Reach distance	23.2		in.
m ₁	Ground clearance, laden, below mast	2.75		in.
m ₂	The minimum ground clearance of frame	2.75		in.
Ast	Aisle width ¹⁾ , 1000×1200 pallet crossways	102	106	in.
Ast	Aisle width ¹⁾ , 800×1200 pallet lengthways	103.7	107.6	in.
Wa	Outer turning radius	61.4	65.3	in.
l ₇	Length across wheel arms (exclusive fork)	66.1	70.5	in.
	Tyre type	PU/PU		
	Tyre size, driving wheels	Φ9×3	Φ10.2×4.1	in.
	Tyre size, loading wheels	Φ4×2.8		in.
	Tyre size, caster wheels	--	Φ3.9×2.8	in.
	Wheels, number driving, caster/loading (x=drive wheels)	1x /4	1x 2/4	
b ₁₀	Track width, front,driving side	0	0	in.
b ₁₁	Track width,rear,loading side	39.3	39.3	in.

- 1) Including safety distance a = 200 mm
- 2) Sound pressure level at the driver' s ear 74 dB(A)

Standard Mast Types (mm)				
Mast types	Close Mast height	Free height	lift height	Extended Mast Height
	h1	h2	h3	h4
Two Stage Mast	1940	0	2700	3660
	2090	0	3000	3960
	2240	0	3300	4260
	2390	0	3600	4560
	2590	0	4000	4960
	2740	0	4300	5260
Three Stage Mast	1960	1000	4000	4955
	2130	1170	4500	5455
	2230	1270	4800	5760
	2295	1335	5000	5960
	2460	1500	5500	6460

Service weight (include battery) (kg)

Mast types	Mast height (mm)	Service weight (kg)	
		CQE12	CQE15S
Two Stage Mast	2700	1825	1855
	3000	1835	1865
	3300	1845	1875
	3600	1855	1885
	4000	1865	1895
	4300	1875	1905
Three Stage Mast	4000	2065	2095
	4500	2080	2110
	4800	2090	2120
	5000	2095	2125
	5500	2110	2140

Length across wheel arms

Mast types		CQE12		CQE15S	
		Two Stage Mast	Three Stage Mast	Two Stage Mast	Three Stage Mast
Overall length (minimum) (mm)	I ₁	2191	2203	2310	2320
Aisle width for pallets 1000 × 1200 crossways (mm)	Ast	2592	2600	2692	2700
Aisle width for pallets 800 × 1200 lengthways (mm)	Ast	2633	2644	2734	2744
Aisle width for pallets 1000 × 1200 lengthways (mm)	Ast	2683	2693	2784	2794
Aisle width for pallets 800 × 1200 crossways (mm)	Ast	2468	2475	2569	2575

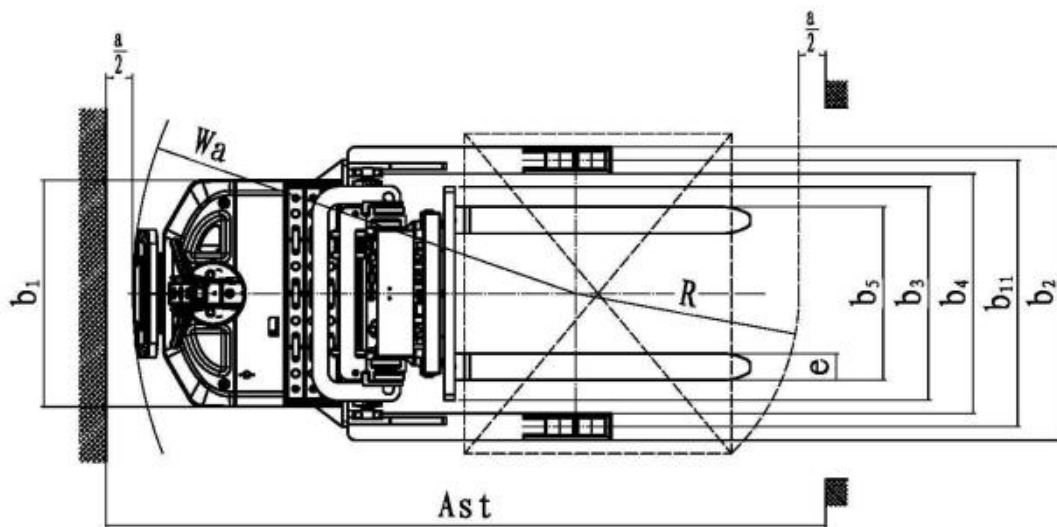
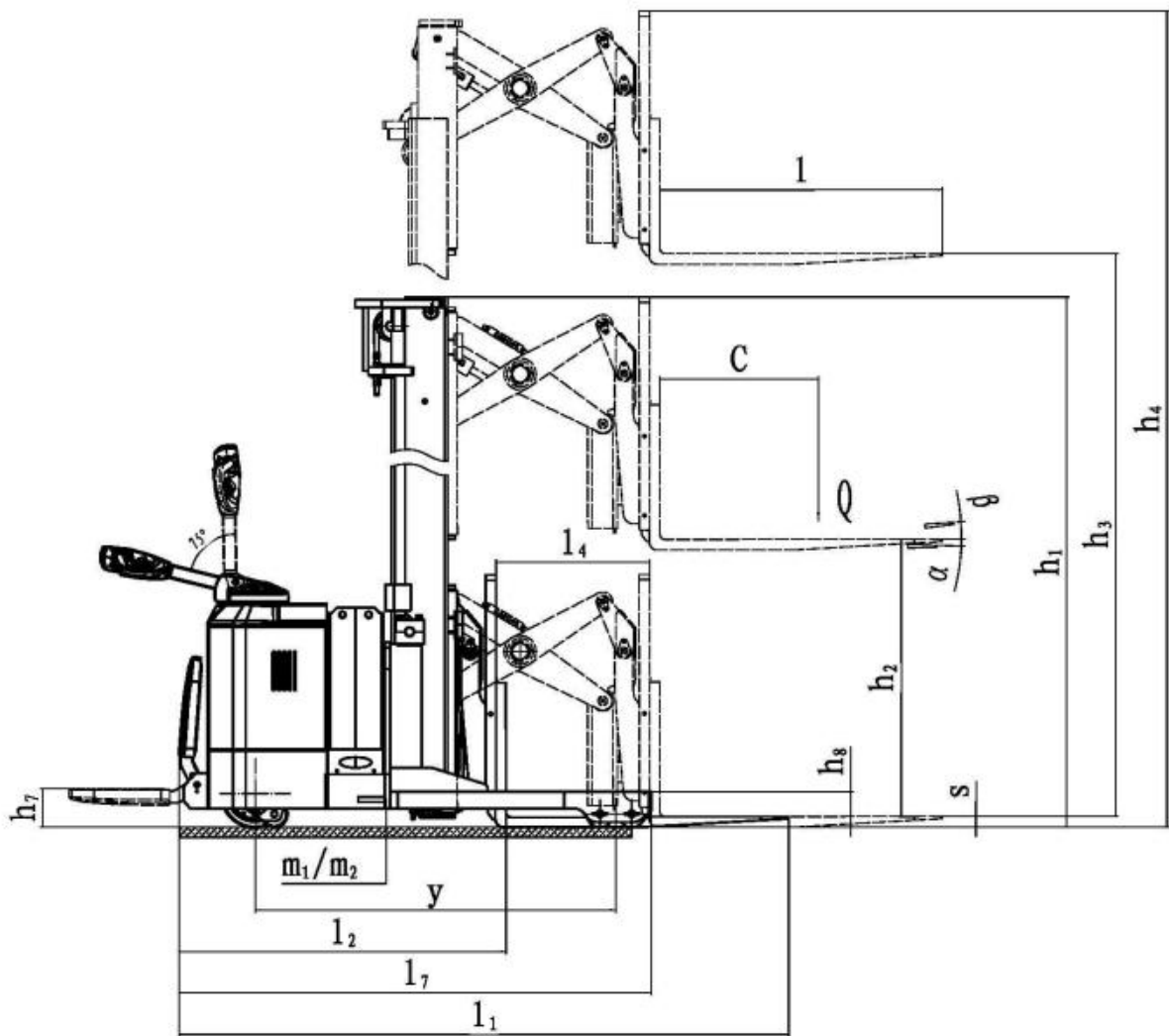

1.4 Identification points and data plates

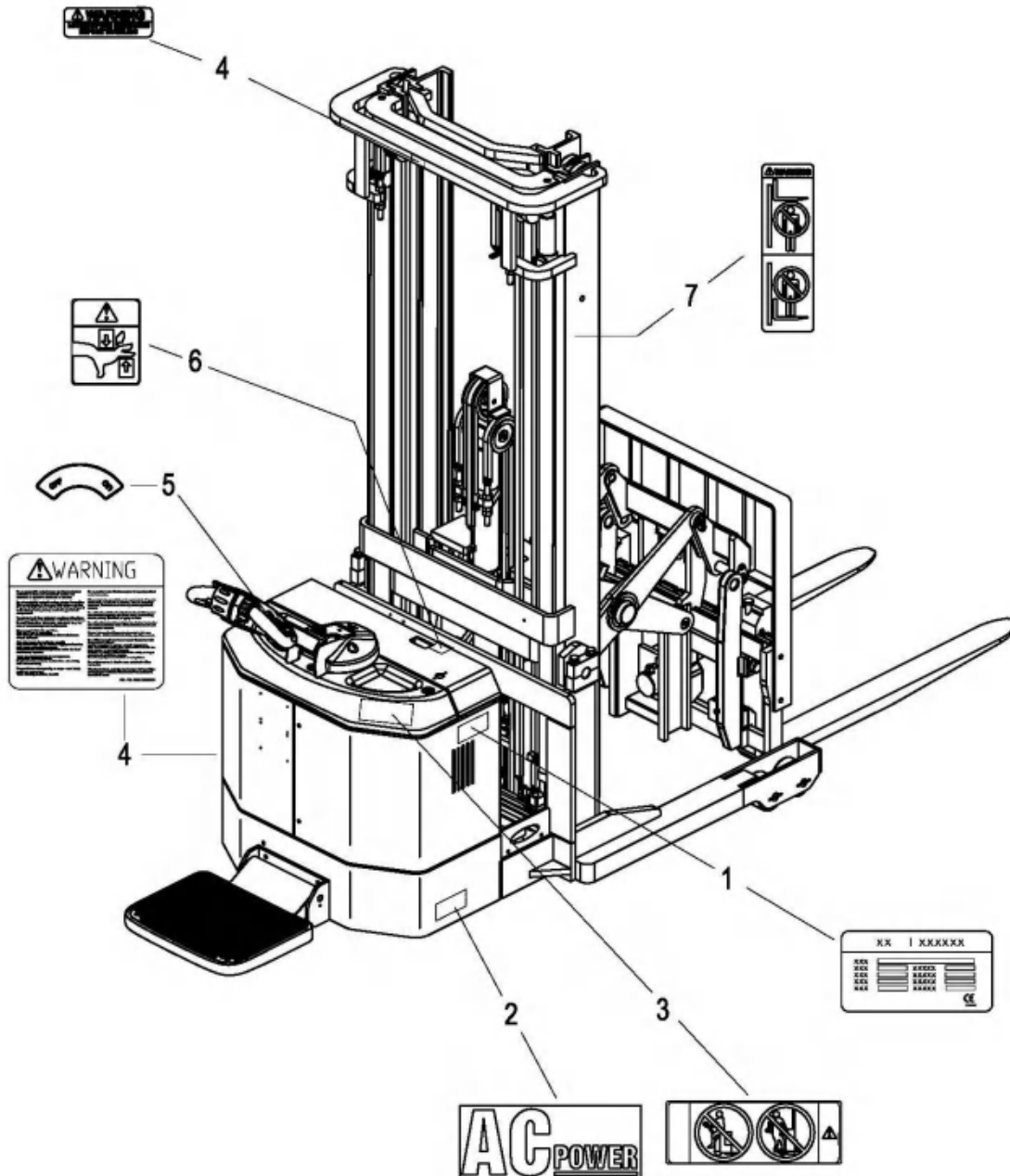

Item	Description	Item	Description
1	Reach Truck data plate	6	"Never put your hands in inner and outer"
2	AC Power Decal	7	"Never stand" warning
3	"Never sit" warning		
4	Operator Warning Decal		
5	Key Switch Decal		

1.4.1 Reach Truck data plate

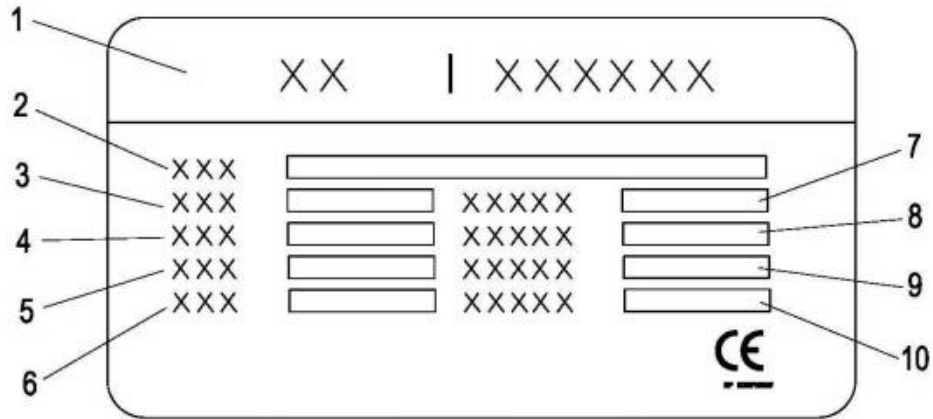

Item	Description	Item	Description
1	Manufacturer	6	Fork length
2	Type	7	Lift height
3	Load capacity (kg)	8	Battery nominate capacity
4	Load center	9	Service weight with battery
5	Fork width	10	Serial no.

For queries regarding the Reach Truck or ordering spare parts please quote the Reach Truck serial number(10).

MODEL NUMBER EXAMPLE

Reach Reach Truck **CQE** **12&15 S**
 Load capacity: 12=1200Kg;
 15=1500Kg

1.4.2 Capacity chart

The chart given above shows the relation between the load center and the weight of loads.

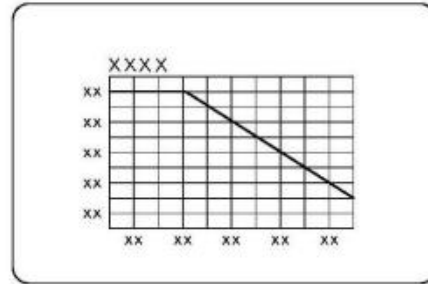

2. Commissioning

2.1 Using the Reach Truck for the First Time

Only operate the Reach Truck with battery current.

Preparing the Reach Truck for operation after delivery or transport.

Procedure

- Check the equipment is complete.
- Check the hydraulic oil level.
- Install the battery if necessary (where required), (see "4.4 Battery removal and installation") do not damage battery cable.
- Charge the battery, (see "4.3 Charging the battery").

When the Reach Truck is parked the surface of the tyres will flatten. The flattening will disappear after a short period of operation.

2.2 During brake-in

We recommended operating the machine under light load conditions for the first stage of operation to get the most from it. Especially the requirements given below should be observed while the machine is in a stage of 100 hours of operation.

- Must prevent the new battery from over discharging when early used. Please charging when remain power less than 20%.
- Perform specified preventive maintenance services carefully and completely.
- Avoid sudden stop, starts or turns.
- Oil changes and lubrication are recommended to do earlier than specified.
- Limited load is 70~80% of the rated load.

3.Operation

3.1 Safety Regulations for the Operation of Reach Trucks

Driver authorisation: The Reach Truck may only be used by suitably trained personnel, who have demonstrated to the proprietor or his representative that they can drive and handle loads and have been authorised to operate the Reach Truck by the proprietor or his representative.

Driver's rights, obligations and responsibilities: The driver must be informed of his duties and responsibilities and be instructed in the operation of the Reach Truck and shall be familiar with the operator manual. The driver shall be afforded all due rights. Safety shoes must be worn with pedestrian operated Reach Trucks.

Unauthorised Use of Reach Truck: The driver is responsible for the Reach Truck during the time it is in use. He shall prevent unauthorised persons from driving or operating the Reach Truck. It is forbidden to carry passengers or lift personnel.

Damage and Faults: The supervisor must be immediately informed of any damage or faults to the Reach Truck. Reach Trucks not safe for operation (e.g. wheel or brake problems) must not be used until they have been rectified.

Repairs: The driver must not carry out any repairs or alterations to the Reach Truck without the necessary training and authorisation to do so. The driver must never disable or adjust safety mechanisms or switches.

Hazardous area: A hazardous area is defined as the area in which a person is at risk due to Reach Truck movement, lifting operations, the load handler (e.g. forks or attachments) or the load itself. This also includes areas which can be reached by falling loads or lowering operating equipment.

- Unauthorised persons must be kept away from the hazardous area.
- Where there is danger to personnel, a warning must be sounded with sufficient notice.
- If unauthorised personnel are still within the hazardous area the Reach Truck shall be brought to a halt immediately.

Safety Devices and Warning Signs: Safety devices, warning signs and warning instructions shall be strictly observed.

3.2 Operate and run the Reach Truck

3.2.1 Preparing

Before the Reach Truck can be commissioned, operated or a load unit lifted, the driver must ensure that there is nobody within the hazardous area.

Checks and operations to be performed before starting daily work

- Make sure the Emergency brake switch is depressed(6).
- Make sure the battery is connected
- Insert the key in the key switch (14) and turn it to the right as far as it will go.
- Test the warning signal switch (13).

Warning!

Before operating the truck, check all controls and warning devices for proper operation. If any damage or fault is found, don't operate truck until corrected.

- Visually inspect the entire Reach Truck (in particular wheels and load handler) for obvious damage.

3.2.2 Travel, Steering, Braking

Do not drive the Reach Truck unless the panels are closed and properly locked.

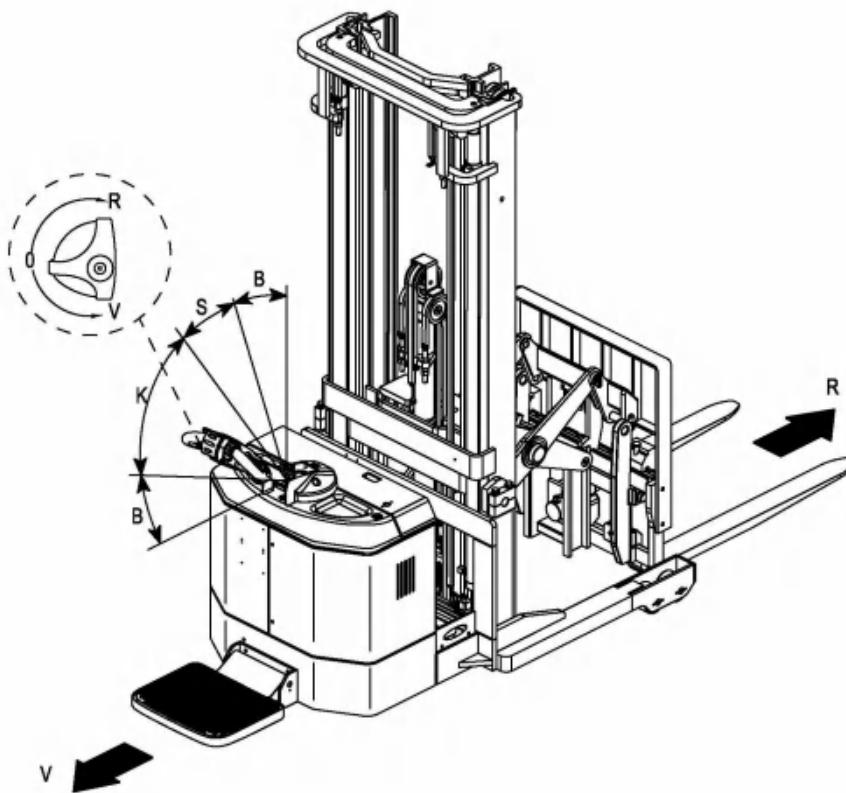

1. Driving

Driving in low speed

Push the control shaft into the slow speed range(S) and set the driving switch to the desired driving direction(front or back).The bigger angle it swivels,the higher speed will it get.

Driving in high speed

Push the control shaft into the quick speed range(K) and set the driving switch to the desired driving direction(front or back). The bigger angle it swivels,the higher speed will it get.

It will get different speed though the switch swivels the same angle in the different range,the speed in the quick range(K) is quicker than in the slow range(S).

2. Steering

Apply the control handle(2) to the left or right.

3. Braking

The brake pattern of the Reach Truck depends largely on the ground conditions. The driver must take this into account when operating the Reach Truck.

The driver must be looking ahead when travelling. If there is no hazard, brake

moderately to avoid moving the load .

The Reach Truck can brake in four different ways:

- Emergency braking
- Automatic braking
- Regenerative braking
- Inversion braking

• Emergency braking

Press Emergency brake switch(1), all electrical functions are cut out and the Reach Truck automatically brakes.

• Automatic braking

When the control handle(2) is released it automatically sets itself to the upper brake zone (B) and automatic braking ensues.

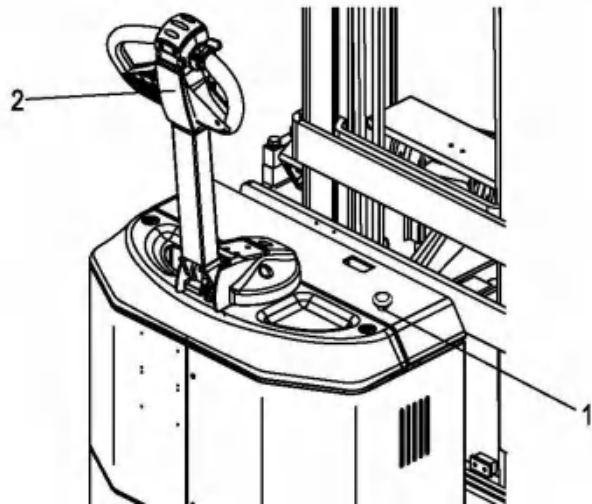

Warning!

If the control handle moves slowly or not at all to the upper brake zone, the Reach Truck must be taken out of service until the cause of this fault is be rectified.

Replace the gas pressure spring if

Warning!

If the travel switch moves slowly or not at all to 0, the Reach Truck must be taken out of service until the cause of this fault is be rectified.

Replace the control handle if necessary.

• **Regenerative braking**

If the travel switch is set to "0", the Reach Truck automatically brakes regeneratively. When the speed below 1Km/h, the brake then applies and motor brake stop.

Warning!

In hazardous situations set the control handle to the brake position or set the travel switch to the opposite direction.

• **Inversion braking**

You can set the travel switch to the opposite direction when travelling. The Reach Truck brakes regeneratively until it starts to move in the opposite direction.

3.2.3 Lifting, transporting and depositing loads

Unsecured and incorrectly positioned loads can cause accidents

- Instruct other people to move out of the hazardous area of the Reach Truck. Stop working with the Reach Truck if people do not leave the hazardous.
- Only carry loads that have been correctly secured and positioned. Use suitable precautions to prevent parts of the load from tipping or falling down.
- Do not transport with bad handbarrow (as Reach Truck and stock) .
- Never stand underneath a raised load handler.
- Do not stand on the load handler.
- Do not lift other people on the load handler.
- Insert the forks as far as possible underneath the load.

Warning!

Before lifting a load unit the driver must make sure that it has been correctly stowed and does not exceed the Reach Truck's capacity. Do not lift long loads at an angle.

Warning!

Don't lift to tiptop, to avoid shorted life of oil cylinder.

Lift

Pull "Lift&Lower" switch(16) until the height you need.

Lower

Push "Lift&Lower" switch(16) until the lowest position.

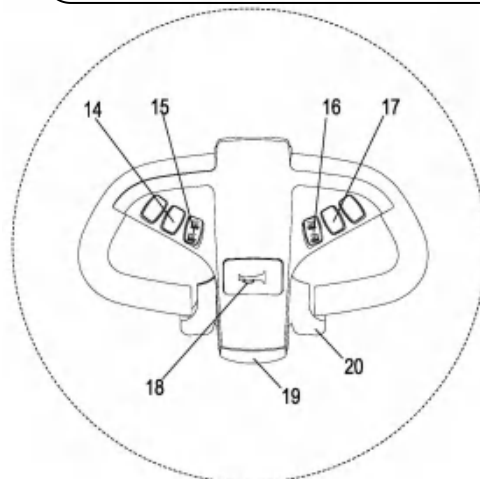

Warning!

- Never tilt the mast with loads upraised 1.5m or more.
- Don't lift the load when the mast was tilted forward.

Tilt forward

Press “Tilting forward&backward” button(15) until the angle you need.

Tilt backward

Press “Tilting forward&backward” button(15) until the angle you need.

3.2.4 Parking the Reach Truck securely

When you leave the Reach Truck it must be securely parked even if you only intend to leave it for a short time.

- Pull “Lower” switch(3), fully lower the load handler.
- Fully lower the forks.
- Press Emergency brake switch(1).
- Turn off the key switch and remove the key(2).

Warning!

Parking the Reach Truck securely.
Forbid parking on an incline.
Always fully lower the forks.

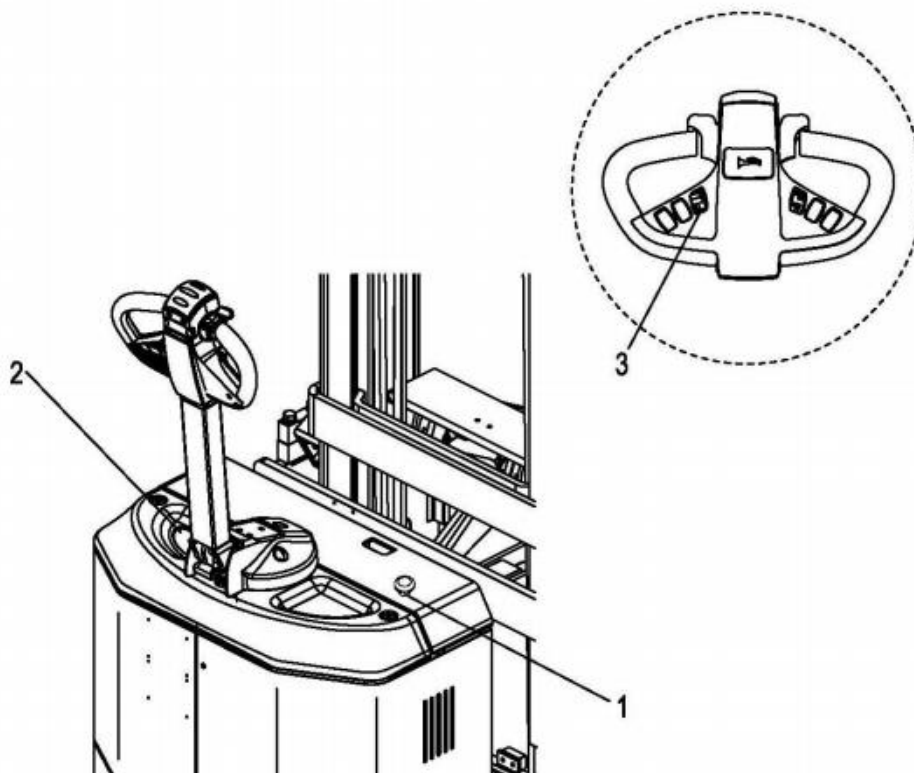

4. Battery Maintenance & Charging

4.1 Safety regulations for handling acid batteries

Park the Reach Truck securely before carrying out any work on the batteries.

Maintenance personnel : Batteries may only be charged, serviced or replaced by trained personnel .The present operator manual and the manufacturer 's instructions concerning batteries and charging stations must be observed when carrying out the work.

Fire protection :

- Smoking and naked flames must be avoided when working with batteries.
- Wherever a Reach Truck is parked for charging there shall be no inflammable material or operating fluids capable of creating sparks within 2 meters around the Reach Truck.
- The area must be well ventilated.
- Fire protection equipment must be provided.



Protection against electric shock:

- Battery has high voltage and energy.
- Do not bring short circuit.
- Do not approach tools to the two poles of the battery, which can cause the sparkle.

4.2 Battery type & dimension

Battery type & dimension as follow :

Tuck type	Battery type	voltage/ rated capacity (V/Ah)	Battery height (in)	Battery length (in)	Battery width (in)
CQE12/15	Industry battery	24 / 210	22.4	25.6	7.8
		24 / 224	26.9	26.2	7.4
		24 / 280	24.8	32.1	8.2
		24 / 360	24.8	32.1	8.2

When replacing or installing batteries, ensure that the battery is correctly secured in the battery compartment of the Reach Truck.

4.3 Charging the battery

Safety regulations for Charging the battery

- To charge the battery, the Reach Truck must be parked in a closed and properly ventilated room.
- Do not place any metal objects on the battery.
- Before charging, check all cables and plug connections for visible signs of damage.
- Before start and finish charging to make sure power is turn OFF.
- It is essential to follow the safety regulations of the battery and charging station manufacturers.

Charging step

- Check whether the condition is according with "Safety regulations for Charging the battery".
- Park the Reach Truck securely(See 3.2.4 Parking the Reach Truck securely).
- Remove the battery plug (1).
- Connect the battery plug (1) with the charging lead of the stationary charger (2) and turn on the charger.

NOTE:This picture is just a sample.

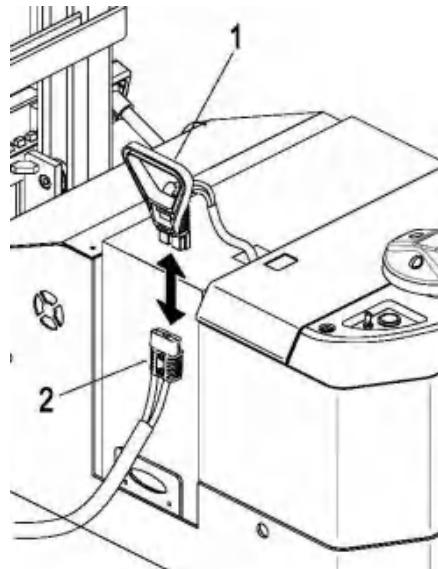

4.4 Battery removal and installation

- Park the Reach Truck securely(See 3.2.4 Parking the Reach Truck securely).
- Place the battery plug(1) or the battery cable in such a way that they will not get caught on the Reach Truck when the battery(3) is removed.
- The hooks must be attached to the eyes of the battery in such a way.
- Remove the baffle(2).Pull the battery out from the side.
- Installation is in the reverse order of operations.

NOTE:This picture is just a sample.

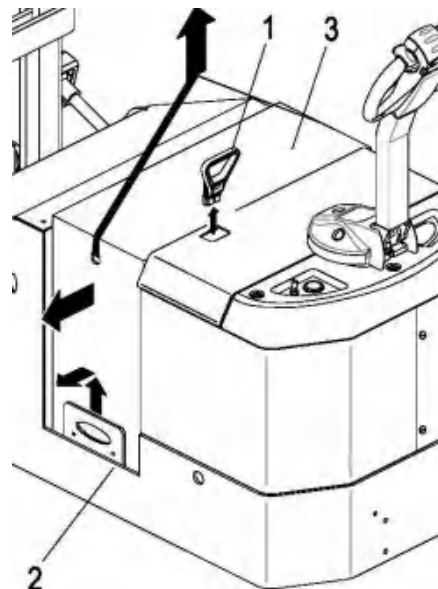

Warning!

The Reach Truck must be parked on level ground. To prevent short circuits, batteries with exposed terminals or connectors must be covered with a rubber mat. When transporting batteries using a crane, ensure that the crane is of adequate Capacity. The lifting gear must exert a vertical pull so that the battery container is not compressed. Forbid falling lift tool on battery surface.

4.5 Battery maintenance

Do not overuse battery:

- If you use up the energy of battery till the forklift immovability, you will shorten its working hours.
- Shower for battery appears need for charge, please charge it quickly.

Battery maintenance:

The battery cell covers must be kept dry and clean. The terminals and cable shoes must be clean, secure and have a light coating of dielectric grease. Batteries with non insulated terminals must be covered with a non slip insulation mat.

Warning!

1. Do not use dry cloth or fabric to clean the battery, avoiding static to bring the explosion.
2. Unfixing battery plug.
3. Cleaning with wet cloth.
4. Wearing glasses for protecting eyes rubber overshoes and rubber glove.

Battery storage:

If batteries are taken out of service for a lengthy period they should be stored in the fully charged condition in a dry, frost-free room. To ensure the battery is always ready for use a choice of charging methods can be made:

- a monthly equalizing charge as in point 4.3 (see Page 18)

4.6 Battery Disposal

Batteries may only be disposed of in accordance with national environmental protection regulations or disposal laws. The manufacturer's disposal instructions must be followed.

Batteries contain an acid solution which is poisonous and corrosive. Therefore, always wear protective clothing and eye protection when carrying out work on batteries. Above all avoid any contact with battery acid.

Nevertheless, should clothing, skin or eyes come in contact with acid the affected parts should be rinsed with plenty of clean water—where the skin or eyes are affected call a doctor immediately. Immediately neutralize any spilled battery acid.

Only batteries with a sealed battery container may be used.

The weight and dimensions of the battery have considerable effect on the operational safety of the Reach Truck. Battery equipment may only be replaced with the agreement of the manufacturer.

5.Reach Truck Maintenance

5.1Operational safety and environmental protection

- The servicing and inspection operations contained in this chapter must be performed in accordance with the intervals indicated in the servicing checklists.
- Any modification to the Reach Truck assemblies, in particular the safety mechanisms, is prohibited. The operational speeds of the Reach Truck must not be changed under any circumstances.
- Only original spare parts have been certified by our quality assurance department. To ensure safe and reliable operation of the Reach Truck, use only the manufacturer's spare parts. Used parts, oils and fuels must be disposed of in accordance with the relevant environmental protection regulations. For oil changes, contact the manufacturer's specialist department.
- Upon completion of inspection and servicing, carry out the activities listed in the "Recommissioning " section.

5.2Maintenance Safety Regulations

Maintenance personnel

Reach Trucks must only be serviced and maintained by the manufacturer's trained personnel.

The manufacturer's service department has field technicians specially trained for these tasks. We therefore recommend a maintenance contract with the manufacturer's local service center.

Lifting and jacking up

When a Reach Truck is to be lifted, the lifting gear must only be secured to the points specially provided for this purpose.

When jacking up the Reach Truck, take appropriate measures to prevent the Reach Truck from slipping or tipping over (e.g. wedges, wooden blocks).

You may only work underneath a raised load handler if it is supported by a sufficiently strong chain.

Cleaning

Do not use flammable liquids to clean the Reach Truck.

Prior to cleaning, all safety measures required to prevent sparking (e.g. through short circuits) must be taken. For battery-operated Reach Trucks, the battery connector must be removed.

Only weak suction or compressed air and non-conductive antistatic brushes may be used for cleaning electric or electronic assemblies.

If the Reach Truck is to be cleaned with a water jet or a high-pressure cleaner, all electrical and electronic components must be carefully covered beforehand as moisture can cause malfunctions.

After cleaning the Reach Truck, carry out the activities detailed in the “Recommissioning” section.

Electrical System

Only suitably trained personnel may operate on the Reach Truck’s electrical system. Before working on the electrical system, take all precautionary measures to avoid – electric shocks.

For battery-operated Reach Trucks, also de-energise the Reach Truck by removing the battery connector.

Welding

To avoid damaging electric or electronic components, remove these from the Reach Truck before performing welding operations.

Settings

When repairing or replacing electric or electronic components or assemblies, always note the Reach Truck-specific settings.

Tyres

The quality of tyres affects the stability and performance of the Reach Truck. When replacing factory fitted tyres only use original manufacturer’s spare parts, as otherwise the data plate specifications will not be kept.

When changing wheels and tyres, ensure that the Reach Truck does not slew (e.g. when replacing wheels always left and right simultaneously).

5.3 Servicing and inspection

Thorough and expert servicing is one of the most important requirements for the safe operation of the Reach Truck. Failure to perform regular servicing can lead to Reach Truck failure and poses a potential hazard to personnel and equipment.

The service intervals stated are based on single shift operation under normal operating conditions. They must be reduced accordingly if the Reach Truck is to be used in conditions of extreme dust, temperature fluctuations or multiple shifts.

The following maintenance checklist states the tasks and intervals after which they should be carried out. Maintenance intervals are defined as:

W = Every 50 service hours, at least weekly

A = Every 250 operating hours

B = Every 500 operating hours, or at least annually

C = Every 2000 operating hours, or at least annually

W service intervals are to be performed by the customer.

In the run-in period - after approx. 100 service hours - or after repair work, the owner must check the wheel nuts/bolts and re-tighten if necessary.

5.3.1 Maintenance Checklist

		Maintenance interval ●			
		W	A	B	C
Braking	Check magnetic brake air gap.			●	
Electrical system	Test instruments, displays and control switches.	●			
	Test warning and safety device.		●		
	Make sure wire connections are secure and check for damage.			●	
	Test micro switch setting.	●			
	Check Controller and EPS Controller.			●	
	Fix the motor and cable			●	
Power supply	Visually inspect battery		●		
	Visually inspect battery plug			●	
	Check battery cable connections are secure, grease terminals if necessary.			●	
Travel	Check the transmission for noise and leakage.			●	
	Check travel mechanism, adjust and lubricate if necessary. Check control handle recuperating function.		●		
	Check driving wheel and loading wheel for wear and damage.			●	
	Check wheel bearings and attachments.			●	
Reach Truck frame	Check Reach Truck frame for damage.			●	
	Check labels are present and complete			●	
	Check mast attachment			●	
Hydraulic operations	Test hydraulic system.		●		
	Check that hose and pipe lines and their connections are secure, check for leaks and damage.		●		
	Check cylinders and piston rods for damage and leaks, and make sure they are secure.			●	
	Check load chain setting and tension if necessary.			●	
	Visually inspect mast rollers and check contact surface wear level			●	
	Check forks, load handler for wear and damage			●	
	Check hydraulic oil level.			●	
	Replace hydraulic oil.				●

5.3.2 Lubrication Schedule

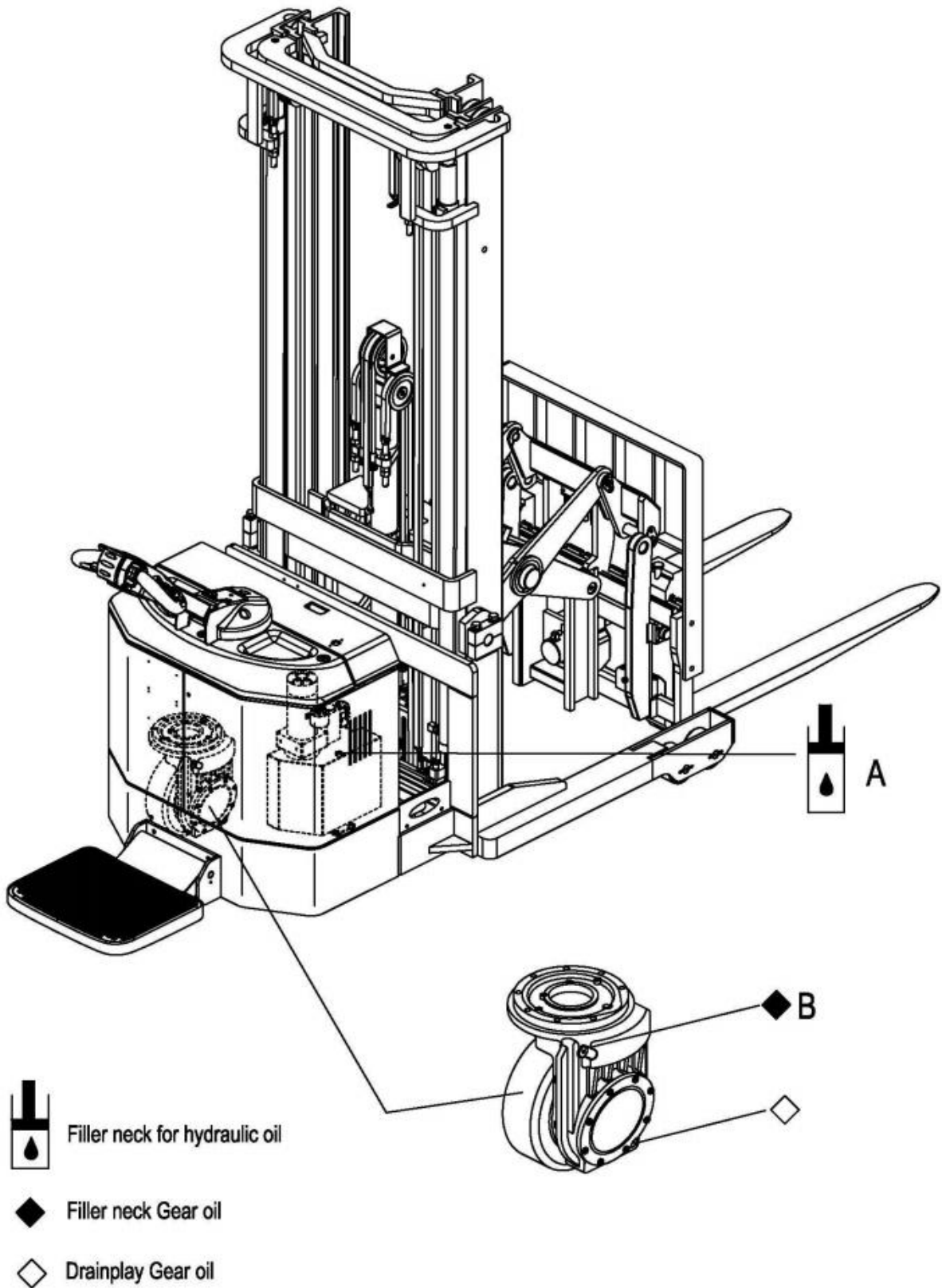

Consumables

Handling consumables type material: Consumables must always be handled correctly. Follow the manufacturer's instructions.

Improper handling is hazardous to health, life and the environment. Consumables must only be stored in appropriate containers. They may be flammable and must therefore not come into contact with hot components or naked flames.

Only use clean containers when filling up with consumables. Do not mix consumables of different grades. The only exception to this is when mixing is expressly stipulated in the Operating Instructions.

Avoid spillage. Spilled liquids must be removed immediately with suitable bonding agents and the bonding agent/consumable mixture must be disposed of in accordance with regulations.

Code	Description	Used for
A	HM32#	Hydraulic system
B	GL-5 85W-90	gear case

5.3.3 Maintenance Instructions

Prepare the Reach Truck for maintenance and repairs

All necessary safety measures must be taken to avoid accidents when carrying out maintenance and repairs. The following preparations must be made:

- Park the Reach Truck securely (See 3.2.4 Parking the Reach Truck securely).
- Remove the key to prevent the Reach Truck from accidentally starting.
- When working under a raised lift Reach Truck, secure it to prevent it from tipping or sliding away.

Open the cover

- Remove the two screws (1).
- Carefully open the panel (2).

Replacing the drive wheel

The drive wheel must only be replaced by authorised service personnel.

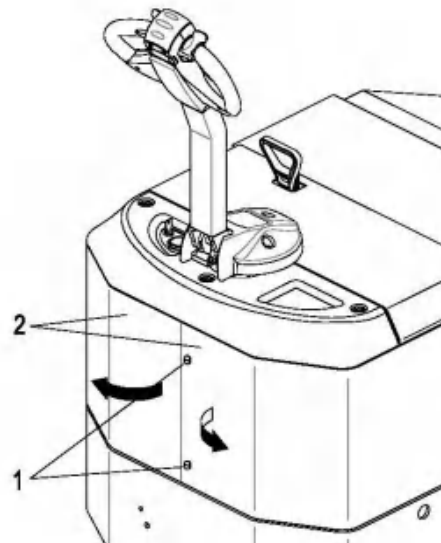

Check the hydraulic oil level

It is going to add hydraulic oil when you heard explosion sound from pipe during lifting.

- Prepare the Reach Truck for maintenance and repairs (See 5.3.3 Maintenance Instructions).
- Opening the front cover
- Add hydraulic oil of the correct grade (See 5.3.2 Lubrication Schedule).

Add hydraulic oil till you cant hear explosion sound during lifting.

Installation is the reverse order.

Warning!

Forbid adding hydraulic oil within impurity.

Check transmission oil level

- Prepare the Reach Truck for maintenance and repairs (See 5.3.3 Maintenance Instructions).
- Open the panel (See 5.3.3 Maintenance Instructions).
- Turn the control handle to the right limited position.
- Check the transmission oil level, it should be at the control plug level (See 5.3.2 Lubrication Schedule).
- Add transmission oil every 800-1000 operating hours, or at least annually (See 5.3.2 Lubrication Schedule).

Installation is the reverse order.

Warning!

Forbid adding transmission oil within impurity.

Checking electrical fuses

- Prepare the Reach Truck for maintenance and repairs (See 5.3.3 Maintenance Instructions).
- Open the front cover.
- Check rating of all fuses in accordance with table, replace if necessary.

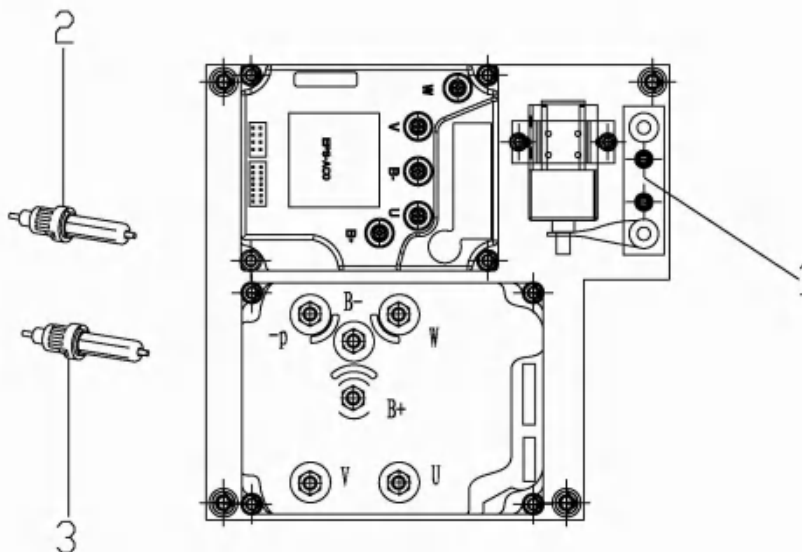

Item	To protect:	Rating
1	Traction/ lifting motor Fuse	200A
2	Battery Control Fuse	10A
3	Control system Control Fuse	10A

Recommissioning

The Reach Truck may only be recommissioned after cleaning or repair work, once the following operations have been performed.

- Test horn.
- Test Emergency brake switch.
- Test brake.
- Lubricate the Reach Truck in accordance with the maintenance schedule.

5.4 Decommissioning the Reach Truck

If the Reach Truck is to be decommissioned for more than two months, e.g. For operational reasons, it must be parked in a frost-free and dry location and all necessary measures must be taken before, during and after decommissioning as described.

On decommissioning the Reach Truck must be jacked up so that all the wheels are clear of the ground. This is the only way of ensuring that the wheels and wheel bearings are not damaged.

If the Reach Truck is to be out of service for more than 6 months, further measures must be taken in consultation with the manufacturer's service department.

5.4.1 Prior to decommissioning

- Thoroughly clean the Reach Truck.
 - Check the brakes.
 - Check the hydraulic oil level and replenish as necessary (See 5.3.3 Maintenance Instructions).
 - Apply a thin layer of oil or grease to any non-painted mechanical components.
 - Lubricate the Reach Truck in accordance with the maintenance schedule (See 5.3.2 Lubrication Schedule).
 - Charge the battery (See 4.3 Charging the battery).
 - Disconnect the battery, clean it and apply grease to the terminals.
- In addition, follow the battery manufacturer's instructions.
- Spray all exposed electrical contacts with a suitable contact spray.

Warning!

Charge every month:

- Charge the battery.

Battery powered Reach Trucks:

The battery must be charged at regular intervals to avoid depletion of the battery through self-discharge. The sulfuration would destroy the battery.

5.4.2 Restoring the Reach Truck to operation after decommissioning

- Thoroughly clean the Reach Truck.
- Lubricate the Reach Truck in accordance with the maintenance schedule (See 5.3.2 Lubrication Schedule).
- Clean the battery, grease the terminals and connect the battery.
- Charge the battery (See 4.3Charging the battery).
- Check hydraulic oil for condensed water and replace if necessary.
- Start up the Reach Truck (see 3.2Operate and run the Reach Truck).

If there are switching problems in the electrical system, apply contact spray to the exposed contacts and remove any oxide layers on the contacts of the operating controls by applying them repeatedly.

Perform several brake tests immediately after re-commissioning the Reach Truck.

5.5 Safety checks to be performed at regular intervals and following any

unusual incidents

Carry out a safety check in accordance with national regulations. EP has a special safety department with trained personnel to carry out such checks. The Reach Truck must be inspected at least annually (refer to national regulations) or after any unusual event by a qualified inspector. The inspector shall assess the condition of the Reach Truck from purely a safety viewpoint, without regard to operational or economic circumstances. The inspector shall be sufficiently instructed and experienced to be able to assess the condition of the Reach Truck and the effectiveness of the safety mechanisms based on the technical regulations and principles governing the inspection of Reach Trucks.

A thorough test of the Reach Truck must be undertaken with regard to its technical condition from a safety aspect. The Reach Truck must also be examined for damage caused by possible improper use. A test report shall be provided. The test results must be kept for at least the next 2 inspections.

The owner is responsible for ensuring that faults are immediately rectified.

A test plate is attached to the Reach Truck as proof that it has passed the safety inspection. This plate indicates the due date for the next inspection.

5.6 Final de-commissioning, disposal

Final, proper decommissioning or disposal of the Reach Truck must be performed in accordance with the regulations of the country of application. In particular, regulations governing the disposal of batteries, fuels and electronic and electrical systems must be observed.

6.Troubleshooting

This chapter is designed to help the user identify and rectify basic faults or the results of incorrect operation. When locating a fault, proceed in the order shown in the table.

Fault	Possible cause	Action
Reach Truck does not start.	<ul style="list-style-type: none">• Key switch in “OFF” position• Battery charge too low• Faulty fuse• Reach Truck in charge mode	<ul style="list-style-type: none">• Set key switch to “I”• Check battery charge, charge battery if Necessary• Test fuses• Interrupt charging
Load can not be lifted	<ul style="list-style-type: none">• Hydraulic oil level too low• Excessive load	<ul style="list-style-type: none">• Check the hydraulic oil level• Note maximum capacity (see data plate)

If the fault cannot be rectified after carrying out the remedial procedure, notify the manufacturer ' s service department ,as any further troubleshooting can only be performed by specially trained and qualified service personnel.

6.1 Error Message

COMBIAC0 CONTROLLER

Error Message		Possible cause	Fault elimination
Code	Error text		
99	SLIP PROFILE	There is an error on the choice of the parameters of the slip profile.	Check in the hardware setting menu the value of those parameters.
80	FORW+BACK	This alarm occurs when both the travel demands (Fwd and Bwd) are active at the same time.	Check the wiring of the Fwd and Rev travel demand inputs (use the readings in the TESTER to facilitate the troubleshooting). Check the microswitches for failures. A failure in the logic is possible too. So, when you have verified the travel demand switches are fine working and the wiring is right, it is necessary to replace the controller.
79	INCORRECT START	This is a warning for an incorrect starting sequence.	The possible reasons for this alarm are (use the readings in the TESTER to facilitate the troubleshooting): A) A travel demand active at key on B) Presence man sensor active at key on Check the wirings. Check the micro-switches. It could be also an error sequence made by the operator. A failure in the logic is possible too; so when all of the above conditions were checked and nothing was found, replace the controller.

78	VACC NOT OK	The test is made at key-on and after 20sec that both the travel demands have been turned off. This alarm occurs if the ACCELERATOR reading in the TESTER menu' is 1,0V higher than PROGRAM VACC min acquisition when the accelerator is released.	Check the mechanical calibration and the functionality of the potentiometer.
62	HIGH TEMPERATURE	This alarm occurs when the temperature of the base plate is higher than 85°. Then the maximum current decreases proportionally with the temperature increases from 85° up to 105°. At 105° the Current is limited to 0 Amps.	Improve the air cooling of the controller. If the alarm is signalled when the controller is cold, the possible reasons are a thermal sensor failure or a failure in the logic card. In this case, it is necessary to replace the controller.
65	BATTERY LOW	It occurs when the battery charge is calculated being less than or equal to 10% of the full charge and the BATTERY CHECK setting is other than 0 (refer to SET OPTION menu).	Get the battery charged. If it doesn't work, measure with a voltmeter the battery voltage and compare it with the value in the BATTERY VOLTAGE parameter. If they are different adjust the value of the ADJUST BATTERY function.
71	EEPROM KO	It's due to a HW or SW defect of the non-volatile embedded memory supporting the controller parameters. This alarm does not inhibit the machine operations, but the truck will work with the default values.	Try to execute a CLEAR EEPROM operation (refer to Console manual). Switch the key off and on to check the result. If the alarm occurs permanently, it is necessary to replace the controller. If the alarm disappears, the previously stored parameters will have been replaced by the default parameters.

65	MOTOR TEMPERATURE	This warning occurs when the temperature sensor is opened (if digital) or has overtaken the threshold of 150°C (if analog).	Check the thermal sensor inside the motor (use the MOTOR TEMPERATURE reading in the TESTER menu); check the sensor ohmic value and the sensor wiring. If the sensor is OK, improve the air cooling of the motor. If the warning is present when the motor is cool, then the problem is inside the controller.
61	THERMIC SENSOR KO	The output of the controller thermal sensor is out of range.	This type of fault is not related to external components; replace the controller.
	CHECK UP NEEDED	This is just a warning to call for the time programmed maintenance.	It is just enough to turn the CHECK UP DONE option to level ON after the maintenance is executed.
	DATA ACQUISITION	Acquisition of the current gains.	The alarm ends when the acquisition is done.
86	PEDAL WIRE KO	The SW continuously checks for the connection of the two supply ends of the potentiometer in the accelerator. The test consists of reading the voltage drop on a sense diode, connected between NPOT (CNA#30) and GND and cascaded with the potentiometer: if the potentiometer gets disconnected on PPOT (CNA#25) or NPOT, no current flows in this sense diode and the voltage on the NPOT connection collapses down. When the NPOT voltage is less than 0.3V this alarm occurs. This alarm occurs also when the NPOT voltage is higher than 2Vdc (to detect also the condition of a broken sense diode).	Check the voltage on NPOT and the potentiometer connections.

51	TILLER OPEN	Warning: when the tiller is released, after a fixed period of time of standby (30 seconds) the main contactor open.	At the next travel request the warning disappear.
92	CURRENT GAIN	The Maximum current gain parameters are at the default values, which means the maximum current adjustment procedure has not been carried out yet.	Ask the assistance of a Zapi technician to do the correct adjustment procedure of the current gain parameters.
68	WAITING FOR NODE	The controller receives from the CAN the message that another controller in the net is in fault condition; as a consequence the ACE0 controller itself cannot enter an operative status, but has to WAIT for the other controller coming out from the fault status.	
98	DEAD MAN ABSENT	This warning (presents only in trucks with "Dead Man" switch) appears when the "Dead Man" switch is open.	At the next travel request with dead man switch close the warning disappears.
76	VALVE COIL SHORTED	This alarm occurs when there is a short circuit on an on/off valve coil.	A) If the fault is present at start up, it is very likely that the hw overcurrent protection circuit is damaged, it is necessary to replace the controller. B) If the fault is present when the controller drives the outputs, the problem is located in the harness and in the coils.
74	EV1/5 DRIVER SHORTED	Electrovalve EV1 or EV2 driver is shorted.	Check if there is a short or a low impedance between the negative of one of those coils and -BATT. Otherwise the driver circuit is damaged and the controller must be replaced.

74	EV2 DRIVER SHORTED	Electrovalve EV2 driver is shorted.	<p>Check if there is a short or a low impedance between the negative of this coil and –BATT. This warning occurs also if the external load is not present and the parameter EV2 in the “Set Options” menu is set “PRESENT”, in this case the warning disappears setting the EV2 parameter “ABSENT”. Otherwise the driver circuit is damaged and the controller must be replaced.</p>
74	EV3 DRIVER SHORTED	Electrovalve EV3 driver is shorted.	<p>Check if there is a short or a low impedance between the negative of this coil and –BATT. This warning occurs also if the external load is not present and the parameter EV3 in the “Set Options” menu is set “PRESENT”, in this case the warning disappears setting the EV3 parameter “ABSENT”. Otherwise the driver circuit is damaged and the controller must be replaced.</p>
74	EV4 DRIVER SHORTED	Electrovalve EV4 driver is shorted.	<p>Check if there is a short or a low impedance between the negative of this coil and –BATT. This warning occurs also if the external load is not present and the parameter EV4 in the “Set Options” menu is set “PRESENT”, in this case the warning disappears setting the EV4 parameter “ABSENT”. Otherwise the driver circuit is damaged and the controller must be replaced.</p>

48	EVP DRIVER KO	The EVP valve driver is not able to drive the load (cannot close).	The device or its driving circuit is damaged, replace the controller.
47	EVP2 DRIVER KO	The EVP2 valve driver is not able to drive the load (cannot close).	The device or its driving circuit is damaged, replace the controller.
56	PUMP I NO ZERO	In standby condition (pump motor not driven), the feedback coming from the current sensor in the pump chopper gives a value out of a permitted range,	This type of fault is not related to external components; replace the controller.
52	PUMP I=0 EVER	This test is carried out when the pump motor is running, and it verifies that the current feedback sensor is not constantly stuck to 0.	A) Check the motor connection, that there is continuity. If the motor connection is opened, the current cannot flow, so the test fails and the error code is displayed. B) If everything is ok for what it concerns the motor, the problem could be in the current sensor or in the related circuit.
49	LIFT + LOWER	This alarm occurs when both forks movement requests(Lift + Lower) are active at the same time.	Check the wiring of the Lift and lower inputs (use the readings in the TESTER to facilitate the troubleshooting). Check the microswitches for failures. A failure in the logic is possible too. So, when you have verified the travel demand switches are fine working and the wiring is right, it is necessary to replace the controller.
75	CONT. DRV. EV1	The EV1 valve driver is not able to drive the load (cannot close).	The device or its driving circuit is damaged, replace the controller.
75	CONT. DRV. EV2	The EV2 valve driver is not able to drive the load (cannot close).	The device or its driving circuit is damaged, replace the controller.

75	CONT. DRV. EV3	The EV3 valve driver is not able to drive the load (cannot close).	The device or its driving circuit is damaged, replace the controller.
75	CONT. DRV. EV4	The EV4 valve driver is not able to drive the load (cannot close).	The device or its driving circuit is damaged, replace the controller.
75	CONT. DRV. EV5	The EV5 valve driver is not able to drive the load (cannot close).	The device or its driving circuit is damaged, replace the controller.
89	PUMP VACC NOT OK	The minimum of the lift potentiometer is not correctly set.	It is suggested to repeat a "PROGRAM VACC" procedure.
67	SENS. MOT. TEMP. KO	A) The motor temperature sensor is not correctly connected to A22. B) The motor temperature sensor is damaged.	- Check the correct connection of the motor temperature sensor. - If the current sensor is correctly connected, replace it. - If the problem persist, it is due to the controller.

EPS-AC0 CONTROLLER

Error Message		Possible cause	Fault elimination
Error	Error text		
6	SERIAL ERR #1	Main uC and Slave uC communicate via a local serial interface. This alarm occurs when the slave uC does not receive the communication from the main uC through this serial interface.	It is necessary to replace the controller.

13	EEPROM KO	It occurs if a test to write and read one location in EEPROM fails. The SW expects to read the written value. It occurs also when the hour counter gives different values between the three redundant locations in which it is recorded. It occurs also when the busy bit of the EEPROM does not rise within 12 msec.	It is necessary to replace the controller.
16	LOGIC FAILURE #4	This alarm occurs in the rest state if the output of the voltage amplifier of the phase Vw-Vv have a drift larger than ± 0.25 V.	It is necessary to replace the controller.
17	LOGIC FAILURE #3	This alarm occurs in the rest state if the output of the voltage amplifier of the phase Vu-Vw have a drift larger than ± 0.25 V.	It is necessary to replace the controller.
18	LOGIC FAILURE #2	This alarm occurs when the real voltage between phases W and V of the motor is different from the desired.	It is necessary to replace the controller.
19	LOGIC FAILURE #1	This alarm occurs when the real voltage between phases W and U of the motor is different from the desired.	It is necessary to replace the controller.
32	VMN NOT OK	This alarm occurs in the initial rest state after key on if the outputs of the motor voltage amplifiers are not in the window from 2.2 to 2.8 Vdc.	It is necessary to replace the controller.

48	MAIN CONT. OPEN	This alarm occurs only when the setting CAN BUS is PRESENT. Then the eps-ac0 waits for a via CAN information that the traction controller has closed the main contactor. If this information lacks more than about 1.5 secs, this alarm occurs.	Find, on the traction controller, the reason for keeping the main contactor open.
53	STBY I HIGH	This alarm occurs two ways: 1) In the initial rest state after key on, if the outputs of the current amplifiers are not comprised in the window 2.2 to 2.8 Vdc. 2) After the initial diagnosis this alarm occurs when the outputs of the current amplifiers at rest have a drift larger than ± 0.15 V.	It is necessary to replace the controller.
61	HIGH TEMPERATURE	This alarm occurs if the temperature of the controller base plate overtakes 75 degrees.	Improve the cooling of the controller; otherwise it is necessary to replace the controller.
65	MOTOR TEMPERAT.	This alarm occurs only when DIAG MOTOR TEMP is on and the thermal sensor inside the motor measures a temperature higher than 150 degrees. It occurs also when trying to acquire the motor resistance with a temperature in the motor higher than 150 degree (still with DIAG MOTOR TEMP to ON).	Check the thermal sensor in the motor is right working. If it is, improve the cooling of the motor.

70	HIGH CURRENT	This alarm occurs if the circuit to limit via hardware the current in the motor is either always active at key-on or repeatedly active when the motor is turning.	Check the motor is suited to work with the eps-ac0 (not oversized). Otherwise it is necessary to replace the controller.
71	POWER FAILURE #3	This alarm occurs when the current in the phase V of the motor is zero and the motor is commanded for moving.	Check the power fuse is OK. Check the battery positive arrives to the controller. Check the continuity of the wire in the phase V of the motor. Otherwise it is necessary to replace the controller.
72	POWER FAILURE #2	This alarm occurs when the current in the phase U of the motor is zero and the motor is commanded for moving.	Check the power fuse is OK. Check the battery positive arrives to the controller. Check the continuity of the wire in the phase U of the motor. Otherwise it is necessary to replace the controller.
73	POWER FAILURE #1	This alarm occurs when the current in the phase W of the motor is zero and the motor is commanded for moving.	Check the power fuse is OK. Check the battery positive arrives to the controller. Check the continuity of the wire in the phase W of the motor. Otherwise it is necessary to replace the controller.
83	BAD ENCODER SIGN	It occurs in applications with toggle switches when the applied frequency (FREQUENCY) and the motor speed (ENC SPEED) have opposite sign.	Swap in between the two encoder channels (CNB#7 with CNB#8).

84	STEER SENSOR KO	This alarm occurs if the command potentiometer (CPOC1 on CNA#9 or CPOC2 on CNA#8) changes with a jerk larger than MAX SP SLOPE (see 12.4.6.3). This alarm is used to catch a discontinuity in the voltages of the command potentiometer.	Change the twin pot.
85	STEER HAZARD	This is just a warning to inform that the steering controller is limiting the angle in the steering direction. No speed reduction occurs on the traction.	---
218	CLOCK PAL NOT OK	The main uC sends an analog signal towards the slave uC to reset the slave uC on demand. When the slave uC detects this analog signal external to a window from 2.2 to 2.8 and not in the range to generate the reset on demand, the slave uC raises this alarm.	It is necessary to replace the controller.

99	INPUT ERROR #1	It occurs when the voltage on CNA#4 (NK1: Lower Potential Terminal of the Safety Contacts (see 7.6) is higher than 12 V before to turn the safety contacts closed.	When the safety contacts are open, the voltage on CNA#4 is expected to be close to 0 Vdc and this is independent from whether the safety contacts are connected to a plus battery or to a minus battery . In the first case (safety contacts connected to a plus battery), when the safety contacts are open, CNA#4 is connected to a minus battery through a load. Only a harness mistake may connect NK1 to a higher than 12 V voltage.
212	MICRO SLAVE #8	It occurs when the encoder counting of the main uC is not matched with the encoder counting of the slave uC.	It is necessary to replace the controller.
219	STEPPER MOTOR MISM	This alarm occurs if the frequency and the amplitude of the voltages from the stepper motor lines are mismatched in between In normal condition when the amplitude of the stepper motor lines increases, the frequency of the stepper motor lines must increase too.	It is necessary to replace the controller.
220	MOTOR LOCKED	This alarm occurs if the current in the steering motor stays close to the maximum current longer than 1 sec.	Search for a mechanical problem locking the motor. To make easier the fault catching, set DEBUG OUTPUT to level 11.

221	MICRO SLAVE #4	<p>It occurs in one of the following conditions: (Open loop application only) If the slave uC detects the stator voltage phasor rotates in the opposite direction respect to the sign of the stepper motor speed, this alarm occurs. (Closed loop application only) If the slave uC detects the stator voltage phasor rotates in the opposite direction respect to the commanded position, this alarm occurs.</p>	<p>It is necessary to replace the controller.</p>
222	FB POT LOCKED	<p>In application with a feedback potentiometer, this alarm occurs if the feedback potentiometer (CPOT on CNB#6) does not change (or changes in the opposite direction) its value even if commanded to change. In application with toggle switches with ENCODER CONTROL to off, this alarm occurs if the feedback encoder counting does not change its value even if commanded to change.</p>	<p>In application with the feedback potentiometer, verify the feedback potentiometer is not mechanically loosened. Check there is not a mechanical block of the steered wheel. Be sure the wiper has not reached its own electrical limit because of too much angle of the steered wheel. Besides, this alarm may occur at the installation when the motor rotates in the wrong direction turning away from the wished</p>
223	JERKING FB POT	<p>This alarm occurs if the feedback potentiometer (CPOT on CNB#6) changes with a jerk larger than 0.3 V in 16 msec. This alarm is used to catch a discontinuity in the voltages of the feedback potentiometer.</p>	<p>Change the feedback potentiometer.</p>

225	CURRENT GAIN	This alarm occurs when the parameters to compensate for the gain of the current amplifiers (ADJUSTMENT #03 and ADJUSTMENT #04) have the default values	It is necessary to send the controller to Zapi to perform the maximum current regulation.
226	NO SYNC	Every 16msec, inside the code cycle, the main uC rises and then lowers an input for the slave uC (SYNC). When the slave uC detects no edge for more than 100 msec on this input, this alarm occurs. This is just a watch dog function: when the main uC does not execute the code cycle it does not update the SYNC signal and the slave uC cuts off the steer and traction.	It is necessary to replace the controller.
227	SLAVE COM. ERROR	Main uC and Slave uC communicate via a local serial interface. This alarm occurs when the main uC does not receive the communication from the slave uC through this serial interface.	It is necessary to replace the controller.
237	WAITING DATA	This warning occurs only if CAN BUS is PRESENT. At key-on the eps-ac0 asks to the traction controller to send a list of parameters via CAN Bus. From the request until the parameters are correctly relieved, this warning occurs. The steer is not activated yet, and the safety relays remain open when this warning is present.	---

228	POSITION ERROR	This alarm occurs for an error in the redundant test of the feedback sensors.	Check the potentiometer connected to CNB#6 is right working. If toggle switches are connected to CNA#2 and CNA#3, verify they are right working and the setting AUX FUNCTION 11 is correct. Verify also the sensor bearing in the motor (encoder) has not a slip (the sensor bearing has two rings: one is connected to the rotor shaft; the other is connected to the motor frame. Check these two rings are strictly connected to their structure without slip.
238	EPS NOT ALIGNED	This is a real alarm that cut off the traction. It occurs at the initial alignment if the straight-ahead condition is not matched within 6sec. Throughout this 6 secs delay, the steer is not activated yet, the safety relays are open and the traction is stopped.	---
239	WAITING FOR TRAC	At key-on the eps-ac0 needs an assent from the traction controller to close the safety contacts and to turn onto operational mode. Until this assent is not relieved, this warning occurs. The steer is not activated yet and the safety relays remain open when this warning is present.	---

241	ENCODER ERROR	It occurs when ENCODER CONTROL is set ON and the real frequency does not pursuit the commanded frequency	This condition is several times due to either, a mismatching between the Encoder resolution used in the SW and the real encoder resolution, or a wrong connection between the two encoder channels. In this latest case exchange in between the two encoder channels.
242	Q LINE SENSOR KO	This alarm occurs when the mean voltage on the Quadrature line of the stepper motor (connection CNA#8) is not null: the voltage on every stepper motor line is a sine wave with null mean voltage.	Check the continuity of the stepper motor connections. In particular the resistance between CNA#8 and the minus battery (with the stepper motor at rest) is expected being very low (close to 30 ohms).
243	D LINE SENSOR KO	This alarm occurs when the mean voltage on the Direct line of the stepper motor (connection CNA#9) is not null: the voltage on every stepper motor line is a sine wave with null mean voltage.	Check the continuity of the stepper motor connections. In particular the resistance between CNA#9 and the minus battery (with the stepper motor at rest) is expected being very low (close to 30 ohms).
245	DATAACQUISITION	This alarm occurs when the acquiring the motor resistance or when adjusting the parameters to compensate for the gain of the current amplifiers (maximum current factory adjusted).	Recycle the key.

244	GAIN EEPROM KO	<p>The parameters to compensate for the gain of the current amplifiers (ADJUSTMENT #03 and ADJUSTMENT #04) are recorded in a not volatile memory (eeprom) with a redundant handling. In fact every adjustment is recorded in three eeprom locations. If the values in these three locations are different in between this alarm occurs.</p>	<p>It is necessary to send the controller to Zapi to execute the maximum current regulation.</p>
246	MICRO SLAVE KO	<p>In stepper motor application, this alarm occurs if the main uC is detecting a direction of the stepper motor not matched with the one that the slave uC is detecting.</p> <p>In closed loop application, this alarm occurs if the main uC is detecting a direction of the steering error not matched with the one that the slave uC is detecting.</p> <p>Furthermore, this alarm occurs also if the main uC is detecting no steering limitation meanwhile the slave uC is detecting a steering limitation.</p>	<p>It is necessary to replace the controller.</p>
247	CAN BUS KO	<p>This alarm occurs only when the setting CAN BUS is PRESENT. Then the eps-ac0 must receive the event messages from the traction controller. If these messages lack more than about 1 sec, this alarm occurs.</p>	<p>Check the CAN Bus communication system and analyse the frames from the traction controller to the steer controllers.</p>

248	S.P OUT OF RANGE	This alarm occurs for a fault on the command potentiometer (CPOC1 on CNA#9, CPOC2 on CNA#8). When a single command pot is chosen, the alarm occurs if its wiper (CPOC1) exits the range from 0.8 Vdc to 4.2 Vdc. When the twin pot is chosen, the alarm occurs if the sum of the two wiper voltages (CPOC1+CPOC2) exits the range from 4.5 Vdc to 5.5 Vdc.	Check the connections of the potentiometer. This alarm occurs when one connection of the command potentiometer is broken.
249	F.B OUT OF RANGE	This alarm occurs for a fault on the feedback potentiometer (CPOT on CNB#6). This alarm occurs if CPOT exits the range from 0.3 Vdc to 4.7 Vdc.	Check the connections of the feedback potentiometer. This alarm occurs when one connection of the feedback potentiometer is broken.
250	MICRO SLAVE	It occurs when the information on the status bus between the main uC and the slave uC is frozen to the 0xFF value (the slave uC does not update the status bus configuration).	It is necessary to replace the controller.
251	KM OPEN	This alarm occurs if the slave uC detects the safety contact, of the main uC, open when expected being closed.	It is necessary to replace the controller.
252	KS OPEN	This alarm occurs if the main uC detects the safety contact, of the slave uC, open when expected being closed.	It is necessary to replace the controller.

253	KM CLOSED	<p>This alarm occurs at key on if the slave uC detects the safety contact, of the main uC, closed prior to be commanded.</p>	<p>This alarm occurs if the connection CNA#5 (K1) is around a voltage of 12 Vdc when switching on the key. In fact, when the safety contacts are open, K1 is expected being connected to a battery voltage (not 12 V). Search for a harness problem or replace the controller.</p>
254	KS CLOSED	<p>This alarm occurs if the main uC detects the safety contact, of the slave uC, closed prior to be commanded.</p>	<p>This alarm occurs if the connection CNA#4 (NK1) is around a voltage of 12 Vdc when switching on the key. In fact, when the safety contacts are open, NK1 is expected being connected to a minus battery voltage (not 12 V). Search for a harness problem or replace the controller.</p>